



TEKNİK MÜHENDİSLİK MAKİNA İMALAT SAN. TİC. LTD. ŞTİ.

ilkim group

KAUÇUK
RUBBER

RULMAN
BEARING

HİDROLİK
HYDRAULIC

PNÖMATİK
PNEUMATIC

www.ilkimgrup.com



FAALİYET ALANLARIMIZ

- ELEKTRİK-TRAFO
- VANA
- İŞ MAKİNALARI LİF TAMİR TAKIMLARI
- HİDROLİK POMPA TAMİR TAKIMLARI
- C. WOLF TAMİR TAKIMLARI
- KULE DÖNÜŞ TAMİR TAKIMLARI
- YÜRÜYÜŞ TAMİR TAKIMLARI
- MOTOR KULAK TAKOZLARI
- VİSRASYON TAKOZLARI
- TOZ KEÇELERİ
- BURÇLAR
- PİSTON KEÇELERİ
- PİN GRES KEÇELERİ
- CENTER JOINT KEÇELERİ
- TEFLON YATAKLAR
- KIRICI KEÇE TAKIMLARI
- KAPLİNLER
- TRAKTÖR TAMİR TAKIMLARI VE KABİN TAKOZLARI
- O-RING (VİTON SİLİKON 70 SH 90 SH)
- YAĞ KEÇELERİ
- BETON POMPA YEDEKLERİ
- LASTİK PİSTON TAKOZLARI
- KEÇE TAKIMLARI
- KELEPÇE CONTALARI
- SANTRAFÜŞ KAPLİNLERİ
- POMPA KAPLİNLERİ
- OLUK LASTİKLERİ
- ŞUT LASTİKLERİ
- KELEPÇE CONTALARI
- BASKI CONTALARI
- VİSRASYON TAKOZLARI
- TEMİZLEME TOPLARI
- BETON POMPA KEÇE TAKIMLARI
- SANTRAL TOZ LASTİKLERİ

HERTÜRLÜ ÖZEL İMALAT İŞLERİ ATÖLYEMİZDE İTİNAYLA YAPILIR



ilkim
kauçuk



ilkim
rulman

ilkim
hidrolik
pneomatik

TEKNİK MÜHENDİSLİK MAKİNA İMALAT SAN. TİC. LTD. ŞTİ.
ilkim group

TEKNİK MÜHENDİSLİK MAKİNA İMALAT SAN. TİC. LTD. ŞTİ.

ilkim group



Şener GENÇER
General Manager



Özgür GENÇER

HAKKIMIZDA

İlkim Group Teknik Mühendislik Makina İml. San. Tic. Ltd. Şti.

İLKİM Grup, ülkemizde Trafo sektörü, Kesici-Yük ayırıcılar, Beton köşk, Vana sektörü, Beton pompası ve Mikser yedek parçaları üretimi ile kauçuk ve plastik enjeksiyon kalıpları baskıları, imalat ve satış sonrası destek konularında lider bir marka olmak amacıyla Ankara'da kurulmuştur. İLKİM Grup, kuruluş amacını gerçekleştirmek ve sektörün ihtiyaçlarını karşılamak amacıyla, kendi bünyesinde bulunan kalıp hanesi, baskı hanesi ve CNC makineleri ile müşteri istekleri doğrultusunda birinci sınıf işçilik ile seri ve özel imalat yapan bir firmadır. Her türlü kauçuk ve plastik ürünün kalıp tasarımı ve imalatı yapabilecek makine ve ekipmana sahip firmamız, müşteri memnuniyetini kendine hedef alarak, yüksek kaliteli ürün çeşitleri, uzman personel, kaliteli hammadde ve tecrübe ile ürünlerimizin kalitesini garanti altına almıştır. Yurt içinde özellikle elektrik, vana ve inşaat sektöründe marka bilinirliği yüksek ve iyi bir imaja sahip olan İLKİM Grup, yurtdışında da aynı güveni sağlamanın gururunu yaşamaktadır. Her geçen gün artan tecrübemiz ve yeni teknolojiler ile *ilkim group* markasını yurt içinde ve yurt dışında en üst seviyelere çıkarmak için titiz çalışmalarımızı sürdürmekteyiz.

ilkim group yönetimi



İÇİNDEKİLER

SIZDIRMAZLIK TEKNOLOJİLERİ	04-07
O-RİNG ÇEŞİTLERİ VE SETLERİ	08
TRAFO SEKTÖRÜ - YÜK AYIRICILAR	09-12
VANALAR	13-15
MULTİ GASKET TRACTOR SPARE PARTS	16-19
KAUÇUK ÖZEL İMALATLAR	20-23
PLASTİK ÖZEL İMALATLAR	24-26
SİLİKON ÖZEL İMALATLAR	27-28
POLIÜRETAN ÖZEL İMALATLAR	29-31
KÖRÜKLER	32-33
DİYAFRAM	34
A TİPİ TİTREŞİM TAKOZU	35
B TİPİ TİTREŞİM TAKOZU	36
C TİPİ TİTREŞİM TAKOZU	37
D TİPİ TİTREŞİM TAKOZU	38
E TİPİ TİTREŞİM TAKOZU	39
KONİK-AT MAKARA-AYAK TİP TİTREŞİM TAKOZU	40
SÜNGER CONTALAR	41-42
EPDM CONTALIK ÜRÜNLER	43
FİTİL GRUBU	44
KAUÇUK CONTALIK ÜRÜNLER	45
SIZDIRMAZLIK CONTALIK ÜRÜNLER	46
CONTALIK ÜRÜNLER	47-49
KLİNGİRİT LEVHALAR	50-51
SIYIRICI CONTALIK ÜRÜNLER	52
DÖŞEMELİK ÜRÜNLER	53
MANTAR LEVHALAR	54
TEFLON KUMAŞ-PRESLİ YÜN KEÇELER	55
OTOMATİK PNÖMATİK FİTINGSLER	56
PNÖMATİK VALFLER	57
PNÖMATİK SİLİNDİRLER VE BAĞLANTI ELEMANLARI	58
PNÖMATİK ÜRÜNLER	59
HORTUM ÇEŞİTLERİ	60
İGS BAĞLANTI ELEMANLARI	61-62
PUTZMAISTER	63-77
SCHWİNG	78-92
REİCH	93-95
SERMAC	96-100
CİFA	101-104
TRANSMİKSER	105-108
KIRICILAR	109-111
RULMAN	112-123
RULMAN YATAKLARI	124-125
GÜÇ AKTARIM ELEMANLARI	126
ZİNCİR - DİŞLİ	127
BURÇLAR	128
V KAYIŞLARI	129-130
DÖNER MİL YAĞ KEÇELERİ	131-132

























ÜRÜN PROGRAMI

İlkim No	Ürün İsmi	Resim	Kullanım Bölgesi	Malzeme	İlkim No	Ürün İsmi	Resim	Kullanım Bölgesi	Malzeme
HİDROLİK BOĞAZ SIZDIRMAZLIK ELEMANLARI									
FR200	Düşük Sürtünmeli Boğaz Keçesi		Boğaz	PU	İGS15	Piston Keçesi		Piston	PU NBR
İGS01	Boğaz Packingi		Boğaz	NBR BEZLİ NBR POM	İGS16	Kopakt Set		Piston	NBR BEZLİ NBR POM
İGS04	Boğaz Packingi		Boğaz	NBR BEZLİ NBR POM	İGS17	Piston Keçesi		Piston	PTFE NBR
İGS22	Boğaz Keçesi		Boğaz	PU	İGS18	Kopakt Set		Piston	NBR TPE POM
İGS29	Ön Basınç Ringi		Boğaz	PU POM	İGS19	Ağır Hizmet Piston Keçesi		Piston	PTFE NBR POM
İGS31	Ağır Hizmet Boğaz Keçesi		Boğaz	NBR PU POM	İGS23	Piston Keçesi		Piston	PU
İGS32	Boğaz Keçesi		Boğaz	PU POM	İGS26	Piston Keçesi		Piston	NBR SAC YAY
İGS33	Boğaz Keçesi		Boğaz	PU	İGS40	Piston Keçesi		Piston	PU POM
İGS34	Boğaz Keçesi		Boğaz	NBR BEZLİ NBR TPE, POM	İGS41	Piston Keçesi		Piston	PTFE NBR
İGS35	Boğaz Keçesi		Boğaz	PTFE NBR	İGS42	Kompakt Piston Keçesi		Piston	NBR TPE POM
İGS37	Boğaz Keçesi		Boğaz	NBR BEZLİ NBR POM	İGS43	Piston Keçesi		Piston	NBR BEZLİ NBR POM
İGS38	Boğaz Keçesi		Boğaz	PU	İGS46	Kompakt Piston Keçesi		Piston	PU POM NBR
İGS39	Boğaz Keçesi		Boğaz	NBR BEZLİ NBR	İGS48	Ağır Hizmet Piston Keçesi		Piston	NBR TPE POM
İGS97	Boğaz Keçesi		Boğaz	HNBR	İGS49	Piston Keçesi		Piston	PU NBR
İGS701	Boğaz Keçesi		Boğaz	PTFE, PASLANMAZ	İGS501	Piston Keçesi		Piston	PA NBR
İGS704	Boğaz Keçesi		Boğaz	PTE NBR	İGS502	Kompakt Piston Keçesi		Piston	NBR BEZLİ NBR POM
İGS03	Piston Packingi		Piston	BEZLİ NBR POM	İGS503	Kompakt Piston Keçesi		Piston	NBR TPE POM

İlkim No	Ürün İsmi	Resim	Kullanım Bölgesi	Malzeme	İlkim No	Ürün İsmi	Resim	Kullanım Bölgesi	Malzeme
HİDROLİK BOĞAZ SIZDIRMAZLIK ELEMANLARI					TOZ KEÇELERİ				
İGS504	Kompakt Piston Keçesi		Piston	NBR BEZLİ NBR POM	İGS10	Nutring Dudaklı Toz Keçesi		Boğaz	NBR
İGS505	Kompakt Piston Keçesi		Piston	NBR BEZLİ NBR POM	İGS11	Toz Keçesi		Boğaz	TPE
İGS518	Kompakt Piston Keçesi		Piston	NBR BEZLİ NBR POM	İGS12	Saclı Toz Keçesi		Boğaz	PU SAC
İGS751	Piston Keçesi		Piston	PTFE PASLANMAZ	İGS13	Saclı Toz Keçesi		Boğaz	PU SAC
İGS753	Piston Keçesi		Piston	PTFE NBR	İGS27	Nutring Dudaklı Toz Keçesi		Boğaz	PU
İGS755	Piston Keçesi		Piston	PTFE NBR	İGS94	Toz Keçesi		Boğaz	PU
İGS757	Piston Keçesi		Piston	PTFE NBR	İGS101	Ters Toz Keçesi		Boğaz	PU
HİDROLİK PİSTON-BOĞAZ SIZDIRMAZLIK ELEMANLARI					İGS102	Toz Keçesi		Boğaz	PU SAC
İGS21	Piston Boğaz Keçesi		Boğaz	PU	İGS103	Nutring Dudaklı Toz Keçesi		Boğaz	PU
İGS36	Piston Boğaz Keçesi		Boğaz	NBR BEZLİ NBR	İGS105	Toz Keçesi		Boğaz	POM
İGS95	Piston Boğaz Keçesi		Boğaz	NBR	İGS107	Toz Keçesi		Boğaz	PU
İGS98	Piston Boğaz Keçesi		Boğaz	PU NBR	İGS703	Toz Keçesi		Boğaz	PTFE
İGS114	Piston Boğaz Keçesi		Boğaz	PU NBR	İGS705	Toz Keçesi		Boğaz	PTFE NBR
İGSX	X-Ring		Boğaz	NBR	İGS706	Toz Keçesi		Boğaz	PTFE NBR
TOZ KEÇELERİ					İGS716	Toz Keçesi		Boğaz	PTFE NBR
İGS05	Toz Keçesi		Boğaz	PU	ÖZEL SIZDIRMAZLIK ELEMANLARI				
İGS06	Toz Keçesi		Boğaz	PU	İGS14	V-Ring			NBR
İGS07	Saclı Toz Keçesi		Boğaz	NBR SAC	İGS150	V Magnet Ring		Boğaz	BEZLİ NBR
İGS07	Saclı Toz Keçesi		Boğaz	PU SAC	İGS151	Yüksek Basınç Sızdırmazlık Elemanı Seti		Boğaz	BEZLİ NBR POM PTFE
İGS09	Toz Keçesi		Boğaz	PU					

İlkin No	Ürün İsmi	Resim	Kullanım Bölgesi	Malzeme	İlkin No	Ürün İsmi	Resim	Kullanım Bölgesi	Malzeme
HİDROLİK BOĞAZ SIZDIRMAZLIK ELEMANLARI					PNÖMATİK PİSTON SIZDIRMAZLIK ELEMANLARI				
İGS152 İGS 153	Düşük Basınç Sızdırmazlık Elemanı Seti		Boğaz	BEZLİ NBR POM	İGS25	Pnömatik Piston Keçesi		Piston	NBR SAC
İGS154	Düşük Basınç Sızdırmazlık Elemanı Seti		Boğaz	NBR BEZLİ NBR	İGS50	Pnömatik Piston Keçesi		Piston	NBR
İGS155	Yüksek Basınç Sızdırmazlık Elemanı Seti		Boğaz	POM BEZLİ NBR PA	İGS50	Pnömatik Piston Keçesi		Piston	PU
İGS702	Boğaz Keçesi		Boğaz	PTFE NBR	İGS54	Pnömatik Piston Keçesi		Piston	NBR
İGS752	Piston Keçesi		Piston	PTFE NBR	İGS55	Pnömatik Piston Keçesi		Piston	NBR ALÜMİNYUM
PNÖMATİK BOĞAZ SIZDIRMAZLIK ELEMANLARI					İGS57	Pnömatik Piston Keçesi		Piston	NBR ALÜMİNYUM
İGS30	Pnömatik Toz Boğaz Keçesi		Boğaz	NBR SAC	İGS58	Pnömatik Piston Keçesi		Piston	PU, POM ALÜMİNYUM MIKNATIS, NBR
İGS51	Pnömatik Toz Boğaz Keçesi		Boğaz	PU	İGS59	Pnömatik Piston Keçesi		Piston	NBR
İGS52	Pnömatik Toz Boğaz Keçesi		Boğaz	PU	İGS59	Pnömatik Piston Keçesi		Piston	PU
İGS53	Pnömatik Toz Boğaz Keçesi		Boğaz	NBR	İGS61	Pnömatik Piston Keçesi		Piston	NBR, POM ALÜMİNYUM NBR
İGS53	Pnömatik Toz Boğaz Keçesi		Boğaz	PU	İGS62	Pnömatik Piston Keçesi		Piston	NBR
İGS56	Pnömatik Toz Boğaz Keçesi		Boğaz	NBR TPE	İGS63	Pnömatik Piston Keçesi		Piston	NBR
İGS64	Pnömatik Toz Boğaz Keçesi		Boğaz	PU	İGS65	Pnömatik Piston Keçesi		Piston	NBR
İGS67	Pnömatik Toz Boğaz Keçesi		Boğaz	NBR	İGS66	Pnömatik Piston Keçesi		Piston	NBR
İGS106	Pnömatik Toz Boğaz Keçesi		Boğaz	NBR	İGS506	Pnömatik Piston Keçesi		Piston	NBR
İGS109	Pnömatik Toz Boğaz Keçesi		Boğaz	NBR	İGS761	Pnömatik Piston Keçesi		Piston	PTFE NBR
İGS130	Pnömatik Toz Boğaz Keçesi		Boğaz	NBR	YATAKLAMA ELEMANLARI				
İGS131	Pnömatik Toz Boğaz Keçesi		Boğaz	NBR	İGS68	V-Ring		Boğaz	POM
İGS715	Pnömatik Toz Boğaz Keçesi		Boğaz	PTFE NBR	İGS69	V Magnet Ring		Piston	POM
					İGS71	Yüksek Basınç Sızdırmazlık Elemanı Seti		Boğaz	POM

İlkin No	Ürün İsmi	Resim	Kullanım Bölgesi	Malzeme
YATAKLAMA ELEMANLARI				
İGS73	Piston-Boğaz Yataklamaları		Piston Boğaz	SENTETİK FİBER, POLYESTER RESİN
İGS75	Piston Yataklamaları		Piston Boğaz	PTFE KATKILI SENTETİK FİBER FENOLİK RESİN
İGS76	Spiral Yataklamaları		Piston Boğaz	POLYESTER FİBER, FENOLİK RESİN
İGS77	Boğaz Yataklamaları		Boğaz	POM
İGS78	Piston-Boğaz Yataklamaları		Piston Boğaz	FENOLİK ARAMİD
İGSBT	Bronzlu Teflon Bant Yataklamaları		Piston Boğaz	PTFE
İGSKT	Karbonlu Teflon Bant Yataklamaları		Piston Boğaz	PTFE
İGSPB	Polyester Resin, Bant Yataklamaları		Piston Boğaz	SENTETİK FİBER, POLYESTER RESİN
İGSSB	Piston-Boğaz Yataklamaları		Piston Boğaz	POLYESTER FİBER, FENOLİK RESİN
STATİK SIZDIRMAZLIK ELEMANLARI				
İGS81	Destek Ringi		Piston Boğaz	TPE
İGS82	Statik Sızdırmazlık Keçesi			PU
İGS83	Statik Sızdırmazlık Keçesi			PU
İGS84	Statik Sızdırmazlık Keçesi			PU
İGS85	Statik Sızdırmazlık Keçesi		Piston	PU
İGS86	Statik Sızdırmazlık Keçesi		Piston	PU
İGS87	Rekor Bağlantı Keçesi			NBR
İGS88	Rekor Bağlantı Keçesi			NBR
İGS89	Rekor Bağlantı Keçesi			PU
İGS0	O-Ring		Piston Boğaz	NBR
İGS0	O-Ring		Piston Boğaz	PU

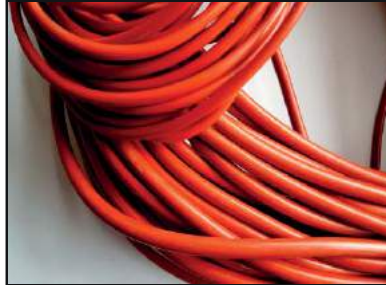
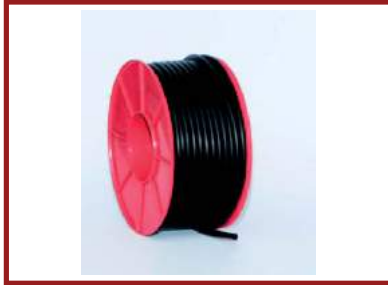
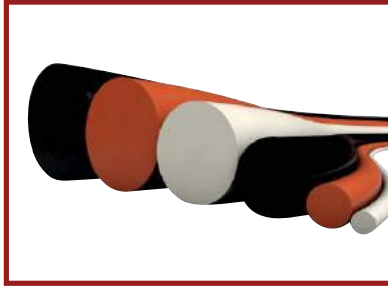
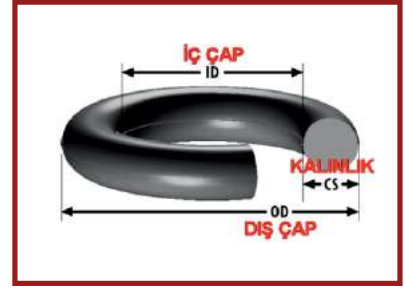

AÇMA-KAPAMA VE KESİCİ BOBİNLERİ



24 kV RMU



24 kV 110 V(DC) RMU

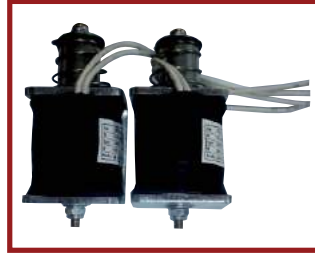

24 kV 220 V(AC) RMU



24 kV RMU 48 V(DC)



36 kV 24 V (DC) Yük Ayırıcı



36 kV 48V (DC)



36 kV 220 V(AC) Yük Ayırıcı

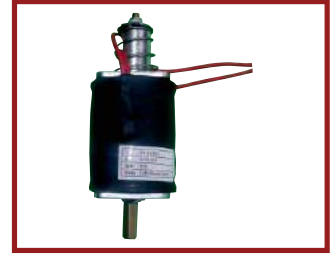

24 V (DC) KESİCİ



36 kV 110 V (DC)



48 V (DC)



110 V (DC)



110 V (DC) RMU



110 V Kesici



220 V (DC) RMU Kesici



RMU V (DC) Vakum Kesici

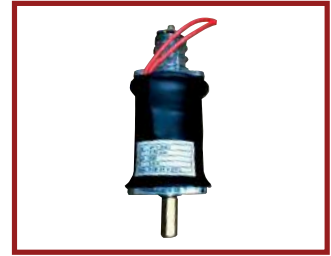

24 V (DC)

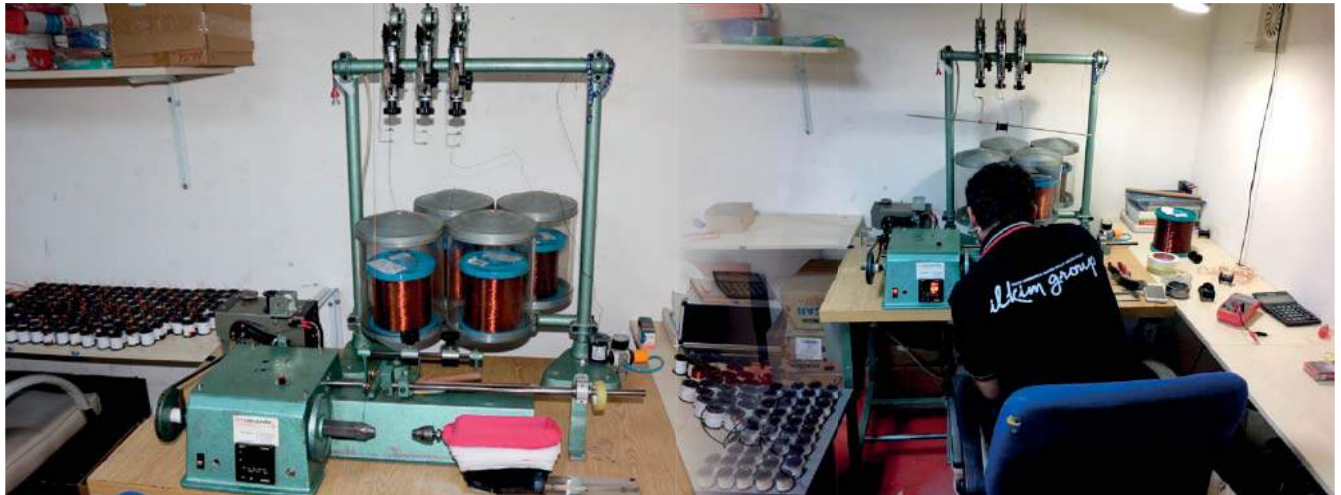

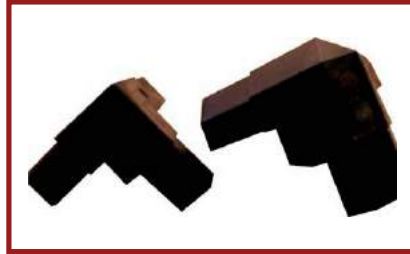
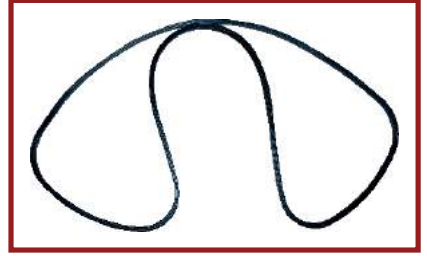
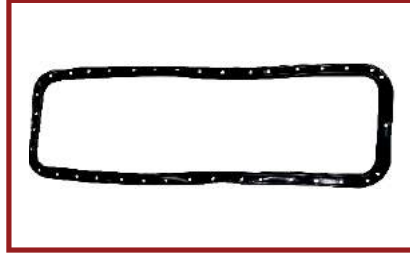
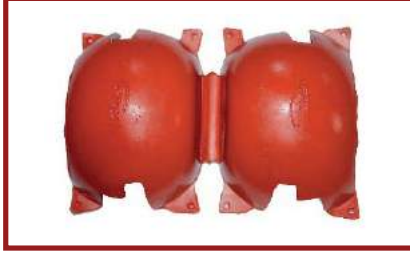

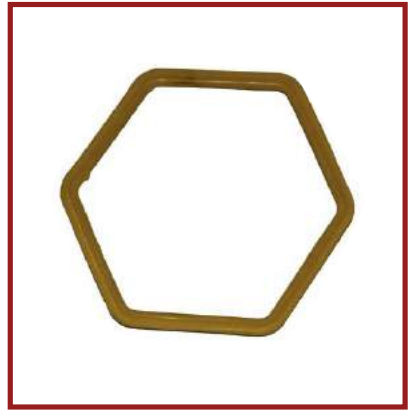
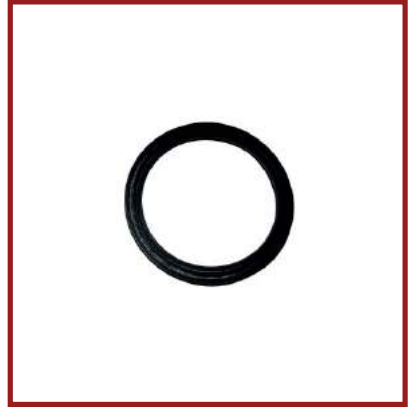
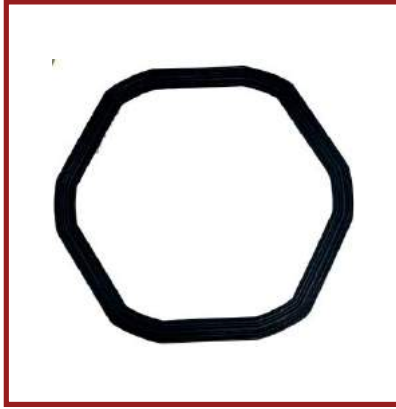



İTHALATLARIMIZ

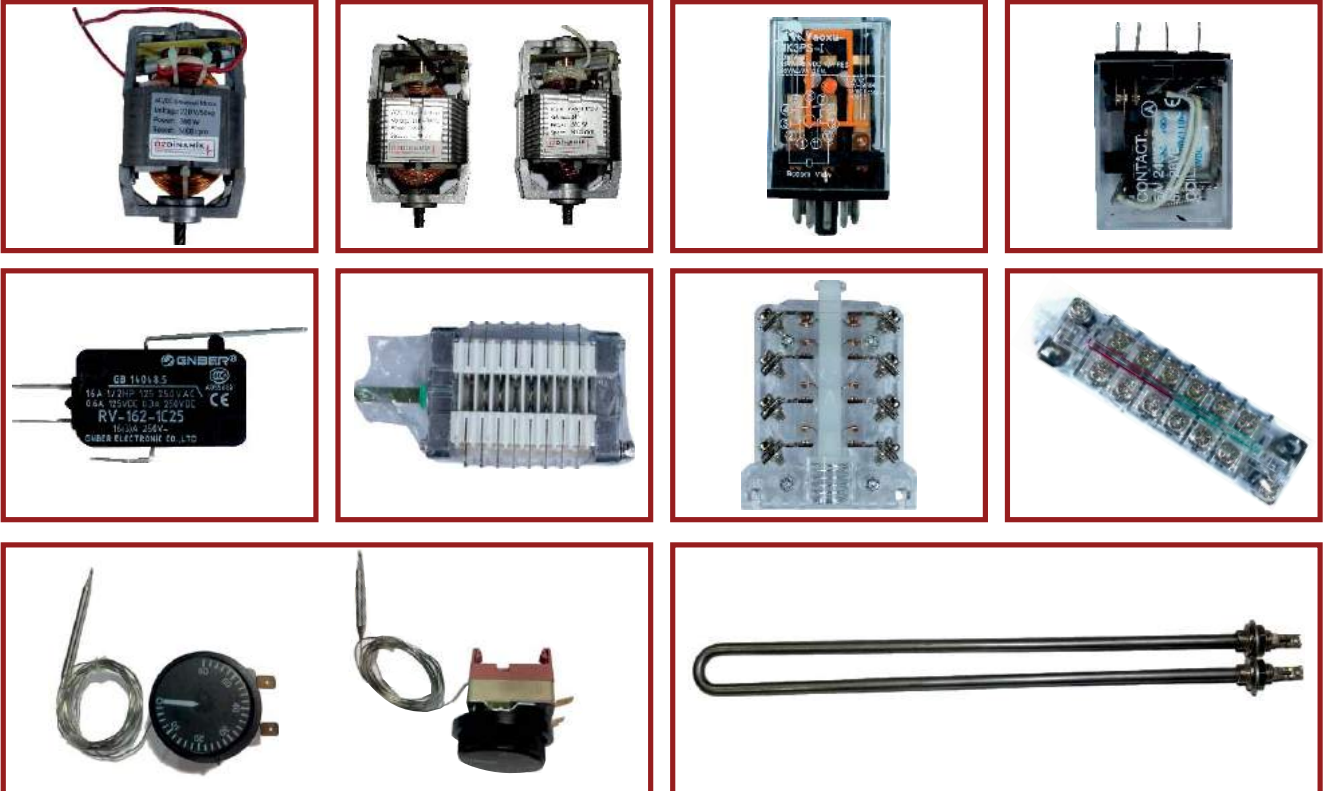

KELEBEK VANA CONTALARI



SÜRGÜLÜ VANA CONTALARI



SÜRGÜLÜ VANA CONTALARI



Sürgülü ve Kelebek Kapak Oringler

40'lık	125'lik
50'lik	150'lik
65'lik	200'lük
80'lik	250'lik
100'lük	300'lük



Flanşlı Vana Contası "d" Montaj Contası

80'lik	450'lik
100'lük	500'lük
125'lik	600'lük
150'lik	700'lük
200'lük	800'lük
250'lik	900'lük
300'lük	1000'lik
350'lik	1200'lük
400'lük	1400'lük



FIAT HYDRAULIC PIPE O-RING GREAT



PART NO: MLT - T023
 REFERENCE NO: 069/14457181

FIAT 55/46 OIL STORAGE HOSE



PART NO: MLT - T008
 REFERENCE NO: 073/5126925

FIAT HYDRAULIC STEERING SEAL KIT

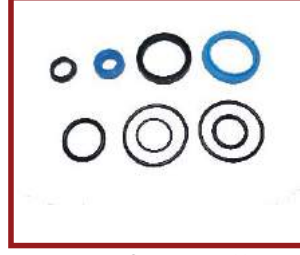

PART NO: MLT - T0119
 REFERENCE NO: FIAT 9961670

FIAT 640 HYDRAULIC RUBBER BLACK



PART NO: MLT - T042
 REFERENCE NO: 014/14472380

FIAT STEERING POWDER RUBBER



PART NO: MLT - T049
 REFERENCE NO: 057/4951213

FIAT ENGINE VENTILATION RUBBER



PART NO: MLT - T044
 REFERENCE NO: 053/4600893

FIAT HYDRAULIC SHIRT RUBBER



PART NO: MLT - T041
 REFERENCE NO: 016/14472680

FIAT STEERING SEAL KIT



PART NO: MLT - T082
 REFERENCE NO: 9961823H

FIAT KAPORTA CHANNEL RUBBER



PART NO: MLT - T025
 REFERENCE NO: 045/4954150

FIAT FUEL FILTER TAIL LARGE



PART NO: MLT - T020
 REFERENCE NO: 050/9918124

FIAT OIL CUSTOMER DUST RUBBER



PART NO: MLT - T063
 REFERENCE NO: FIAT TRACTOR

FIAT VITES SPECIAL RUBBER



PART NO: MLT - T005
 REFERENCE NO: 033/51092222

FIAT AIR FILTER RUBBER

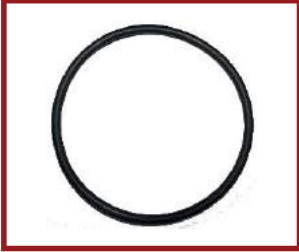

PART NO: MLT - T052
 REFERENCE NO: 024/577706

FIAT INJECTOR LIBRARY RUBBER



PART NO: MLT - T046
 REFERENCE NO: 041/4848654

FIAT 110-90 H00D STRAP RUBBER



PART NO: MLT - T013
 REFERENCE NO: 070-Y/4999154

FIAT KAPORTA RUBBER STRAIGHT



PART NO: MLT - T026
 REFERENCE NO: 046/4950442

FIAT 8066 HYDRAULIC PIPE HOSE



PART NO: MLT - T006
 REFERENCE NO: 075/5118862

FIAT HD ARM TIRE BLACK M. 180



PART NO: MLT - T004
 REFERENCE NO: 007/14471180

FIAT HYDRAULIC BELLOWS RUBBER



PART NO: MLT - T011
 REFERENCE NO: 090/5128133-1

FIAT FUEL FILTER RUBBER SMALL



PART NO: MLT - T045
 REFERENCE NO: 051/9918145

* Orjinal kodlar referans için kullanılmıştır.

FIAT NEW TYPE OF VITES DIP TIRES



PART NO: MLT - T021
 REFERENCE NO: 037-A/4971269

FIAT 55/46 OIL STORAGE HOSE



PART NO: MLT - T008
 REFERENCE NO: 073/5126925

FIAT CABIN CONNECTION WEDGE



PART NO: MLT - T034
 REFERENCE NO: 025/4997423

FIAT TRANSMISSION RUBBER



PART NO: MLT - T018
 REFERENCE NO: 072/98458442

FIAT HYDRAULIC ARM RUBBER GREAT



PART NO: MLT - T031
 REFERENCE NO: 008/1441280

FIAT COVERED PANEL ROLL RUBBER



PART NO: MLT - T027
 REFERENCE NO: 044/4950424

FIAT HYDRAULIC DANFOZ SEAL KIT N.M.

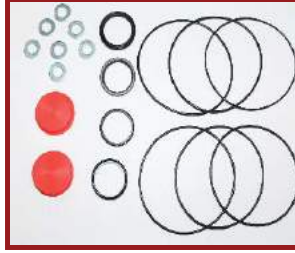

PART NO: MLT - T066
 REFERENCE NO: FIAT TRACTOR

FIAT 640-540 HYDRAULIC SHIRT RUBBER BLACK



PART NO: MLT - T043
 REFERENCE NO: 018/14472880

FIAT AIR SUCTION DUST RUBBER



PART NO: MLT - T036
 REFERENCE NO: 034/599501

FIAT HYDRAULIC SEAL KIT O.M.



PART NO: MLT - T0105
 REFERENCE NO: FIAT 8281576

FIAT SIDE POLISH RUBBER



PART NO: MLT - T019
 REFERENCE NO: 0068/11461280

FIAT INDICATOR RUBBER Y.M



PART NO: MLT - T055
 REFERENCE NO: 070-A/9960218

FIAT SIBOP CAP RUBBER



PART NO: MLT - T052
 REFERENCE NO: 084/8816531

FIAT SIBOP CAP RUBBER



PART NO: MLT - T053
 REFERENCE NO: 083/500301351

FIAT CYCLINDER SEAL KIT



PART NO: MLT - T0111
 REFERENCE NO: FIAT 9960045-1

FIAT SIBOP CAP RUBBER



PART NO: MLT - T084
 REFERENCE NO: 055/4654361

FIAT 640 SIBOP CAP RUBBER



PART NO: MLT - T056
 REFERENCE NO: 056/46554363

FIAT LIFT CYCLINDER SEAL KIT



PART NO: MLT - T0123
 REFERENCE NO: FIAT 9966100

FIAT HYDRAULIC PIPE RUBBER VITON



PART NO: MLT - T047
 REFERENCE NO: 021-V/14457180

FIAT 54C/60/70.56 STEERING PISTON SELA KIT



PART NO: MLT - T088
 REFERENCE NO: FIAT 5080091

FIAT LAMP RUBBER NEW M.



PART NO: MLT - T003
 REFERENCE NO: 026/5122378

FIAT AIR FILTER OUTER RUBBER



PART NO: MLT - T079
 REFERENCE NO: 036/9959751A

FIAT STEERING POWDER TIRE N.M.



PART NO: MLT - T022
 REFERENCE NO: 057-A/5121867

FIAT BREAK FELT POWDER TIRE



PART NO: MLT - T024
 REFERENCE NO: 127/18606559M1

FIAT HYDRAULIC PISTON RUBBER BLACK



PART NO: MLT - T039
 REFERENCE NO: 012/576819

FIAT HYDRAULIC PIPE O-RING RUBBER



PART NO: MLT - T012
 REFERENCE NO: 021/14457180

FIAT HYDRAULIC PUMP SEAL KIT-ANATOLIA TYPE

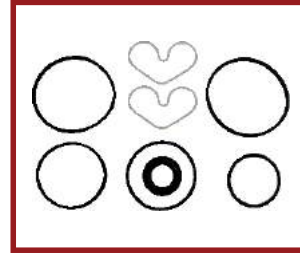

PART NO: MLT - T099
 REFERENCE NO: FIAT 640 TRACTOR

FIAT RADIATOR CONNECTION CABLE



PART NO: MLT - T014
 REFERENCE NO: 082/5108225

FIAT FUEL TANK WEDGE



PART NO: MLT - T030
 REFERENCE NO: 090-1/5097046

FIAT 415 HOSE



PART NO: MLT - T002
 REFERENCE NO: 063/4579906

FIAT ROD DUST RUBBER



PART NO: MLT - T062
 REFERENCE NO: 030-A/4098978

FIAT HYDRAULIC PIPE HOSE



PART NO: MLT - T009
 REFERENCE NO: 071/5085048

FIAT WATER SOURCE FLANGE RUBBER



PART NO: MLT - T059
 REFERENCE NO: FIAT TRACTOR

FIAT RADIATOR WATER CONTAINER L-95



PART NO: MLT - T048
 REFERENCE NO: 066/5122344-1

FIAT GEAR RUBBER CHANNEL NEW M.



PART NO: MLT - T010
 REFERENCE NO: 037/4984223

FIAT WATER TRANSMISSION RUBBER



PART NO: MLT - T038
 REFERENCE NO: 048/14462882

TRAKTÖR KABİN TAKOZLARI

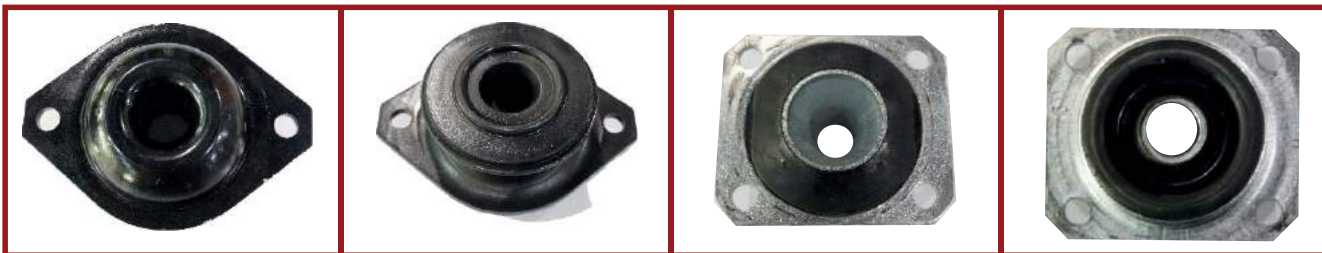

FIAT STEERING WHEEL RATTLING BUSHING



PART NO: MLT - T032
 REFERENCE NO: 058/9956334

FIAT DIMENSIONS RUBBER O.M.



PART NO: MLT - T017
 REFERENCE NO: 037/4971269

FIAT HOOD RUBBER BUTTON



PART NO: MLT - T015
 REFERENCE NO: 047/4950442

FIAT COUPLING RUBBER KIT



PART NO: MLT - T051
 REFERENCE NO: 031/4957107

FIAT HYDRAULIC FILTER COVER RUBBER



PART NO: MLT - T035
 REFERENCE NO: 015/4998331

FIAT ROD DUST RUBBER



PART NO: MLT - T040
 REFERENCE NO: 030/4098978

FIAT HYDRAULIC PISTON RUBBER



PART NO: MLT - T077
 REFERENCE NO: FIAT TRACTOR

FIAT 80 66 HYDRAULIC LIFT SEAL KIT

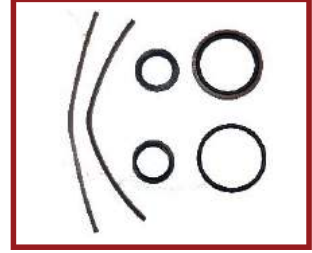

PART NO: MLT - T0116
 REFERENCE NO: FIAT 9961858

FIAT TRANSMISSION DUST RUBBER



PART NO: MLT - T057
 REFERENCE NO: 090-K/5132031-87572560

FIAT BUOY RUBBER



PART NO: MLT - T058
 REFERENCE NO: FIAT TARCTOR

AIR FILTER CHANNEL RUBBER



PART NO: MLT - T007
 REFERENCE NO: 027/599500

FIAT HYDRAULIC BRAIN SEAL KIT

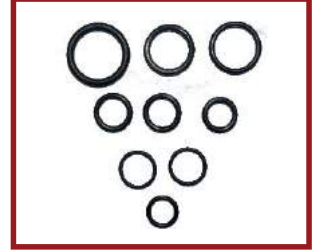

PART NO: MLT - T064
 REFERENCE NO: 82815/8B

FIAT INJECTOR DOMESTIC SILICONE

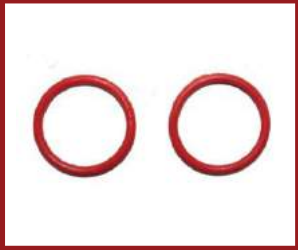

PART NO: MLT - T029
 REFERENCE NO: 043-S/14453981

FIAT TRAILER LIFTING SEAL



PART NO: MLT - T061
 REFERENCE NO: FIAT TRACTOR

FIAT 415 FUEL BOTTLE TIRE



PART NO: MLT - T028
 REFERENCE NO: 052/705631

FIAT KARTER RUBBER



PART NO: MLT - T050
 REFERENCE NO: 022/576628

FIAT VITES POWDER RUBBER



PART NO: MLT - T016
 REFERENCE NO: 074/7999009

FIAT STEERING LIFT SEAL KIT

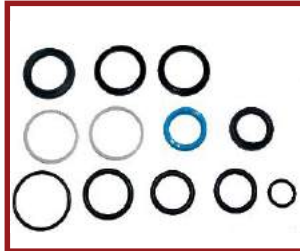

PART NO: MLT - T094
 REFERENCE NO: FIAT TRACTOR

FIAT SIBOP CAP RUBBER CHANNEL



PART NO: MLT - T054
 REFERENCE NO: 054/4601047

FIAT FILTER GLASS RUBBER N.M.



PART NO: MLT - T060
 REFERENCE NO: FIAT TRACTOR







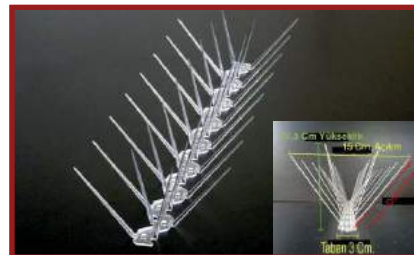

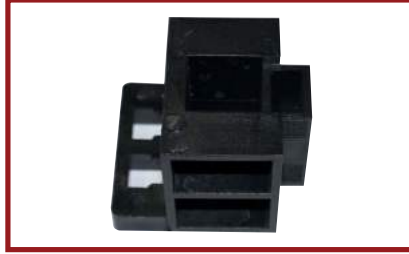
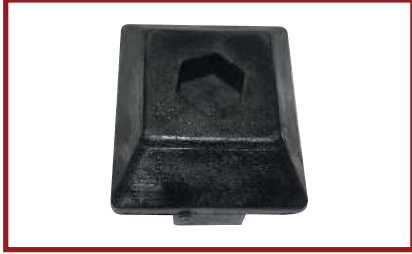
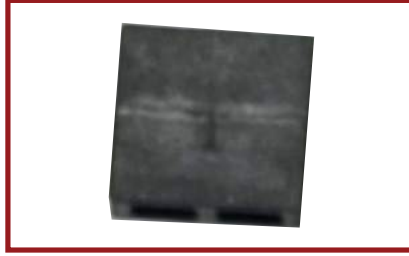
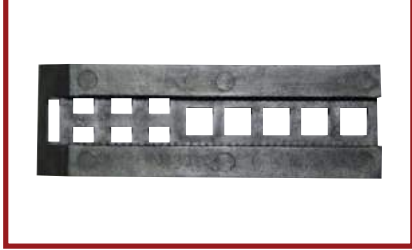



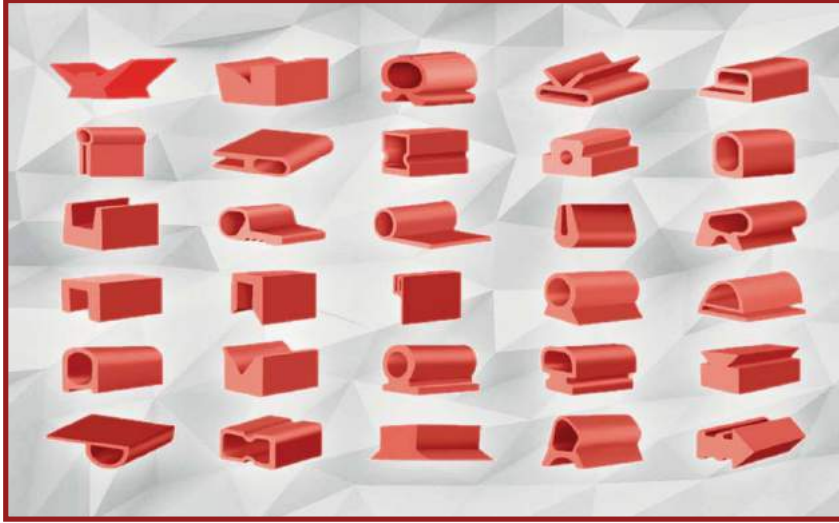



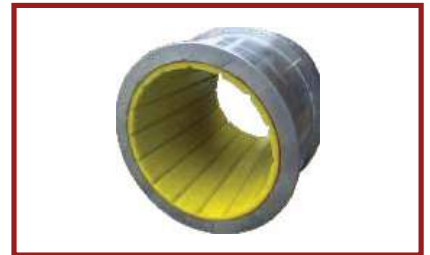
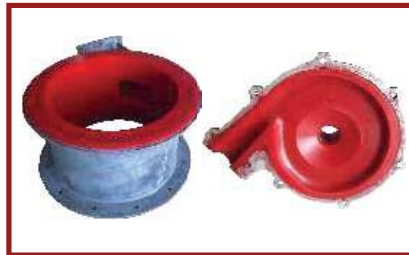



KÖRÜKLER

Özel Siparişleriniz teknik resim ve numunelerinize göre imal edilir.

MALZEME

TABİİ KAÜÇUK - SİLİKON

SERTLİK

30±80 Shore - A

SICAKLIK DAYANIMI

-10°C / +220°C



KR 01

16
ÜST DELİK
16
ALT DELİK
3
KANAT ADEDİ
31
KANAT ÇAPİ
16
TOPLAM BOY



KR 02

5
ÜST DELİK
13
ALT DELİK
8
KANAT ADEDİ
25
KANAT ÇAPİ
56
TOPLAM BOY



KR 03

13
ÜST DELİK
33
ALT DELİK
2
KANAT ADEDİ
41
KANAT ÇAPİ
34
TOPLAM BOY



KR 04

18
ÜST DELİK
31
ALT DELİK
4
KANAT ADEDİ
36
KANAT ÇAPİ
23
TOPLAM BOY



KR 05

11
ÜST DELİK
33
ALT DELİK
2
KANAT ADEDİ
37
KANAT ÇAPİ
25
TOPLAM BOY



KR 06

5
ÜST DELİK
11
ALT DELİK
14
KANAT ADEDİ
23
KANAT ÇAPİ
84
TOPLAM BOY



KR 07

23
ÜST DELİK
23
ALT DELİK
3
KANAT ADEDİ
38
KANAT ÇAPİ
44
TOPLAM BOY



KR 08

16
ÜST DELİK
16
ALT DELİK
7
KANAT ADEDİ
45
KANAT ÇAPİ
80
TOPLAM BOY



KR 09

10
ÜST DELİK
41
ALT DELİK
6
KANAT ADEDİ
57
KANAT ÇAPİ
57
TOPLAM BOY



KR 10

10
ÜST DELİK
28
ALT DELİK
2
KANAT ADEDİ
37
KANAT ÇAPİ
65
TOPLAM BOY



KR 11

8
ÜST DELİK
28
ALT DELİK
3
KANAT ADEDİ
53
KANAT ÇAPİ
53
TOPLAM BOY



KR 12

8
ÜST DELİK
32
ALT DELİK
1
KANAT ADEDİ
39
KANAT ÇAPİ
31
TOPLAM BOY



KR 13

18
ÜST DELİK
43
ALT DELİK
2
KANAT ADEDİ
45
KANAT ÇAPİ
67
TOPLAM BOY



KR 14

8
ÜST DELİK
50
ALT DELİK
5
KANAT ADEDİ
64
KANAT ÇAPİ
57
TOPLAM BOY



KR 15

45
ÜST DELİK
45
ALT DELİK
2
KANAT ADEDİ
62
KANAT ÇAPİ
47
TOPLAM BOY



KR 16

40
ÜST DELİK
62
ALT DELİK
2
KANAT ADEDİ
125
KANAT ÇAPİ
40
TOPLAM BOY



KR 17

8
ÜST DELİK
47
ALT DELİK
2
KANAT ADEDİ
60
KANAT ÇAPİ
41
TOPLAM BOY



KR 18

30
ÜST DELİK
58
ALT DELİK
2
KANAT ADEDİ
70
KANAT ÇAPİ
29
TOPLAM BOY



KR 19

87
ÜST DELİK
87
ALT DELİK
3
KANAT ADEDİ
103
KANAT ÇAPİ
84
TOPLAM BOY



KR 20

37
ÜST DELİK
97
ALT DELİK
3
KANAT ADEDİ
103
KANAT ÇAPİ
60
TOPLAM BOY



KR 21

14
ÜST DELİK
14
ALT DELİK
6
KANAT ADEDİ
31
KANAT ÇAPİ
86
TOPLAM BOY



KR 22

89
ÜST DELİK
120
ALT DELİK
2
KANAT ADEDİ
180
KANAT ÇAPİ
58
TOPLAM BOY



KR 23

32
ÜST DELİK
68
ALT DELİK
8
KANAT ADEDİ
83
KANAT ÇAPİ
200
TOPLAM BOY



KR 24

31
ÜST DELİK
31
ALT DELİK
16
KANAT ADEDİ
95
KANAT ÇAPİ
250
TOPLAM BOY



KR 25

68
ÜST DELİK
123
ALT DELİK
9
KANAT ADEDİ
154
KANAT ÇAPİ
105
TOPLAM BOY



KR 26

40
ÜST DELİK
128
ALT DELİK
5
KANAT ADEDİ
164
KANAT ÇAPİ
210
TOPLAM BOY



KR 27

165
ÜST DELİK
165
ALT DELİK
2
KANAT ADEDİ
220
KANAT ÇAPİ
165
TOPLAM BOY



KR 28

170
ÜST DELİK
170
ALT DELİK
1
KANAT ADEDİ
230
KANAT ÇAPİ
145
TOPLAM BOY



KR 29

73
ÜST DELİK
73
ALT DELİK
1
KANAT ADEDİ
145
KANAT ÇAPİ
136
TOPLAM BOY



KR 30

110
ÜST DELİK
184
ALT DELİK
11
KANAT ADEDİ
245
KANAT ÇAPİ
240
TOPLAM BOY



KR 31

110
ÜST DELİK
110
ALT DELİK
1
KANAT ADEDİ
170
KANAT ÇAPİ
145
TOPLAM BOY



KR 32

52
ÜST DELİK
52
ALT DELİK
1
KANAT ADEDİ
123
KANAT ÇAPİ
145
TOPLAM BOY



KR 33

120
ÜST DELİK
150
ALT DELİK
2
KANAT ADEDİ
188
KANAT ÇAPİ
80
TOPLAM BOY



KR 34

19
ÜST DELİK
29
ALT DELİK
22
KANAT ADEDİ
49
KANAT ÇAPİ
400
TOPLAM BOY



KR 35

225
ÜST DELİK
225
ALT DELİK
4
KANAT ADEDİ
280
KANAT ÇAPİ
220
TOPLAM BOY



KR 36

260
ÜST DELİK
260
ALT DELİK
2
KANAT ADEDİ
320
KANAT ÇAPİ
165
TOPLAM BOY



KR 37

270
ÜST DELİK
270
ALT DELİK
1
KANAT ADEDİ
325
KANAT ÇAPİ
148
TOPLAM BOY



KR 38

315
ÜST DELİK
315
ALT DELİK
1
KANAT ADEDİ
370
KANAT ÇAPİ
145
TOPLAM BOY



KR 39

40
ÜST DELİK
40
ALT DELİK
9
KANAT ADEDİ
67
KANAT ÇAPİ
165
TOPLAM BOY



KR 40

44
ÜST DELİK
50
ALT DELİK
9
KANAT ADEDİ
80
KANAT ÇAPİ
185
TOPLAM BOY



KR 41

25
ÜST DELİK
37
ALT DELİK
6
KANAT ADEDİ
62
KANAT ÇAPİ
200
TOPLAM BOY



KR 42

41
ÜST DELİK
41
ALT DELİK
6
KANAT ADEDİ
63
KANAT ÇAPİ
190
TOPLAM BOY



KR 43

41
ÜST DELİK
46
ALT DELİK
15
KANAT ADEDİ
60
KANAT ÇAPİ
187
TOPLAM BOY



KR 44

39
ÜST DELİK
44
ALT DELİK
25
KANAT ADEDİ
60
KANAT ÇAPİ
300
TOPLAM BOY

diyafram



DYF 01

14
İÇ DELİK
—
DIŞ DELİK AD.
32
GÖBEK ÇAP
57
KENAR ÇAP
8
YÜKSEKLİK



DYF 02

10
İÇ DELİK
—
DIŞ DELİK AD.
48
GÖBEK ÇAP
57
KENAR ÇAP
4
YÜKSEKLİK



DYF 03

6
İÇ DELİK
—
DIŞ DELİK AD.
50
GÖBEK ÇAP
59
KENAR ÇAP
1.5
YÜKSEKLİK



DYF 04

5
İÇ DELİK
2
DIŞ DELİK AD.
50
GÖBEK ÇAP
60
KENAR ÇAP
10
YÜKSEKLİK



DYF 05

—
İÇ DELİK
—
DIŞ DELİK AD.
45
GÖBEK ÇAP
64
KENAR ÇAP
22
YÜKSEKLİK



DYF 06

—
İÇ DELİK
—
DIŞ DELİK AD.
—
GÖBEK ÇAP
65
KENAR ÇAP
3
YÜKSEKLİK



DYF 07

16.5
İÇ DELİK
—
DIŞ DELİK AD.
33
GÖBEK ÇAP
65
KENAR ÇAP
10
YÜKSEKLİK



DYF 08

6.5
İÇ DELİK
—
DIŞ DELİK AD.
51
GÖBEK ÇAP
65
KENAR ÇAP
10
YÜKSEKLİK



DYF 09

—
İÇ DELİK
1
DIŞ DELİK AD.
54
GÖBEK ÇAP
65
KENAR ÇAP
9
YÜKSEKLİK



DYF 10

10
İÇ DELİK
—
DIŞ DELİK AD.
55
GÖBEK ÇAP
67
KENAR ÇAP
14
YÜKSEKLİK



DYF 11

—
İÇ DELİK
—
DIŞ DELİK AD.
39
GÖBEK ÇAP
70
KENAR ÇAP
4.5
YÜKSEKLİK



DYF 12

6
İÇ DELİK
6
DIŞ DELİK AD.
46
GÖBEK ÇAP
70
KENAR ÇAP
7
YÜKSEKLİK



DYF 13

7
İÇ DELİK
6
DIŞ DELİK AD.
30
GÖBEK ÇAP
71
KENAR ÇAP
7
YÜKSEKLİK



DYF 14

—
İÇ DELİK
—
DIŞ DELİK AD.
26
GÖBEK ÇAP
72
KENAR ÇAP
5
YÜKSEKLİK



DYF 15

7
İÇ DELİK
6
DIŞ DELİK AD.
48
GÖBEK ÇAP
72
KENAR ÇAP
5
YÜKSEKLİK

A

TIPI TİTREŞİM TAKOZU

Özel Siparişleriniz teknik resim ve numunelerinize göre imal edilir.

MAZLEME
TABİİ KAUÇUK
SERTLİK
60±5 Shore - A
SICAKLIK DAYANIMI
-20°C / +80 °C

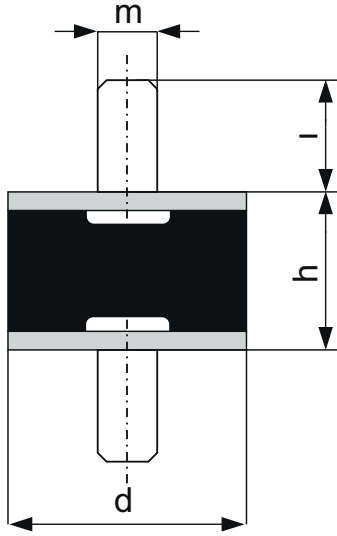

d (mm)	h (mm)	m (mm)	ı (mm)
10	10	4	10
10	15	4	15
15	8	4	10
15	10	4	10
15	15	4	10
20	10	6	15
20	15	6	15
20	20	6	15
20	25	6	15
20	30	6	15
20	40	6	15
25	15	6	18
25	20	6	18
25	25	6	18
25	30	6	18
30	15	8	20
30	20	8	20
30	25	8	20
30	30	8	20
30	40	8	20
35	15	8	20
35	40	8	20
40	20	8	20
40	25	8	20
40	30	8	20
40	40	8	20

d (mm)	h (mm)	m (mm)	ı (mm)
50	20	10	28
50	25	10	28
50	30	10	28
50	40	10	28
50	45	10	28
50	50	10	28
60	30	12	12
60	40	10	28
60	60	12	32
70	40	12	37
75	25	12	37
75	40	12	37
75	50	12	37
75	55	12	37
100	40	16	42
100	50	16	42
100	55	16	42
100	60	16	42
100	75	16	42
150	50	20	42
150	55	20	42
150	60	20	42
150	75	20	42
200	100	20	42



B

Özel Siparişleriniz teknik resim ve numunelerinize göre imal edilir.

MAZLEME
TABİİ KAUÇUK

SERTLİK
60±5 Shore - A

SICAKLIK DAYANIMI
-20°C / +80 °C

TİPİ TİTREŞİM TAKOZU

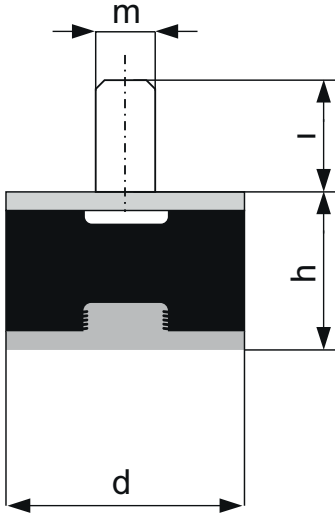

d (mm)	h (mm)	m (mm)	ı (mm)
10	10	4	10
10	15	4	15
15	8	4	10
15	10	4	10
15	15	4	10
20	10	6	15
20	15	6	15
20	20	6	15
20	25	6	15
20	30	6	15
20	40	6	15
25	15	6	18
25	20	6	18
25	25	6	18
25	30	6	18
30	15	8	20
30	20	8	20
30	25	8	20
30	30	8	20
30	40	8	20
35	15	8	20
35	40	8	20
40	20	8	20
40	25	8	20
40	30	8	20
40	40	8	20

d (mm)	h (mm)	m (mm)	ı (mm)
50	20	10	28
50	25	10	28
50	30	10	28
50	40	10	28
50	45	10	28
50	50	10	28
60	30	12	12
60	40	10	28
60	60	12	32
70	40	12	37
75	25	12	37
75	40	12	37
75	50	12	37
75	55	12	37
100	40	16	42
100	50	16	42
100	55	16	42
100	60	16	42
100	75	16	42
150	50	20	42
150	55	20	42
150	60	20	42
150	75	20	42
200	100	20	42





Özel Siparişleriniz teknik resim ve numunelerinize göre imal edilir.

MAZLEME
TABİİ KAUÇUK

SERTLİK
60±5 Shore - A

SICAKLIK DAYANIMI
-20°C / +80 °C

TİPİ TİTREŞİM TAKOZU

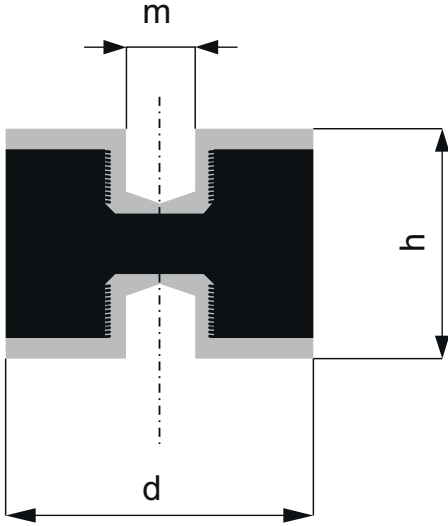

d (mm)	h (mm)	m (mm)
10	10	4
10	15	4
15	8	4
15	10	4
15	15	4
20	10	6
20	15	6
20	20	6
20	25	6
20	30	6
20	40	6
25	15	6
25	20	6
25	25	6
25	30	6
30	15	8
30	20	8
30	25	8
30	30	8
30	40	8
35	15	8
35	40	8
40	20	8
40	25	8
40	30	8
40	40	8

d (mm)	h (mm)	m (mm)
50	20	10
50	25	10
50	30	10
50	40	10
50	45	10
50	50	10
60	30	12
60	40	10
60	60	12
70	40	12
75	25	12
75	40	12
75	50	12
75	55	12
100	40	16
100	50	16
100	55	16
100	60	16
100	75	16
150	50	20
150	55	20
150	60	20
150	75	20
200	100	20



D

Özel Siparişleriniz teknik resim ve numunelerimize göre imal edilir.

MAZLEME
TABİİ KAUÇUK

SERTLİK
60±5 Shore - A

SICAKLIK DAYANIMI
-20°C / +80 °C

TİPİ TİTREŞİM TAKOZU

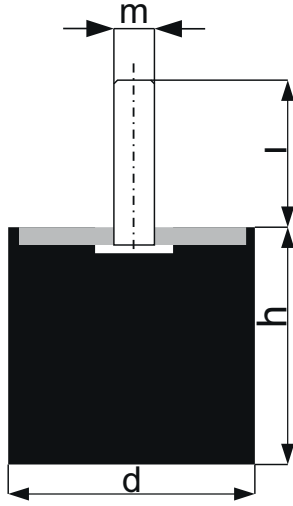

d (mm)	h (mm)	m (mm)	ı (mm)
10	10	4	10
10	15	4	15
15	8	4	10
15	10	4	10
15	15	4	10
20	10	6	15
20	15	6	15
20	20	6	15
20	25	6	15
20	30	6	15
20	40	6	15
25	15	6	18
25	20	6	18
25	25	6	18
25	30	6	18
30	15	8	20
30	20	8	20
30	25	8	20
30	30	8	20
30	40	8	20
35	15	8	20
35	40	8	20
40	20	8	20
40	25	8	20
40	30	8	20
40	40	8	20

D TİPİ TİTREŞİM TAKOZLARI

d (mm)	h (mm)	m (mm)	ı (mm)
50	20	10	28
50	25	10	28
50	30	10	28
50	40	10	28
50	45	10	28
50	50	10	28
60	30	12	12
60	40	10	28
60	60	12	32
70	40	12	37
75	25	12	37
75	40	12	37
75	50	12	37
75	55	12	37
100	40	16	42
100	50	16	42
100	55	16	42
100	60	16	42
100	75	16	42
150	50	20	42
150	55	20	42
150	60	20	42
150	75	20	42
200	100	20	42





Özel Siparişleriniz teknik resim ve numunelerinize göre imal edilir.

MAZLEME

TABİİ KAUÇUK

SERTLİK

60±5 Shore - A

SICAKLIK DAYANIMI

-20°C / +80 °C

TİPİ TİTREŞİM TAKOZU

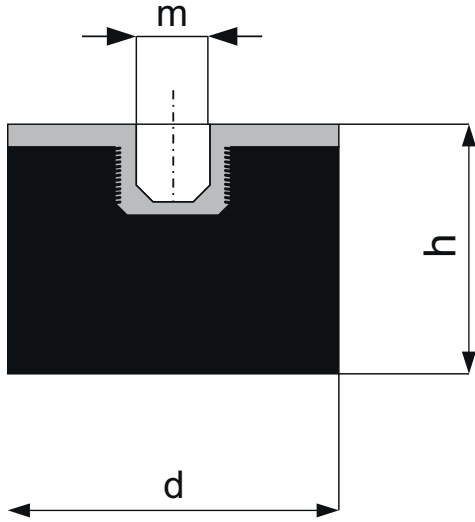

d (mm)	h (mm)	m (mm)
10	10	4
10	15	4
15	8	4
15	10	4
15	15	4
20	10	6
20	15	6
20	20	6
20	25	6
20	30	6
20	40	6
25	15	6
25	20	6
25	25	6
25	30	6
30	15	8
30	20	8
30	25	8
30	30	8
30	40	8
35	15	8
35	40	8
40	20	8
40	25	8
40	30	8
40	40	8

d (mm)	h (mm)	m (mm)
50	20	10
50	25	10
50	30	10
50	40	10
50	45	10
50	50	10
60	30	12
60	40	10
60	60	12
70	40	12
75	25	12
75	40	12
75	50	12
75	55	12
100	40	16
100	50	16
100	55	16
100	60	16
100	75	16
150	50	20
150	55	20
150	60	20
150	75	20
200	100	20



KONİK TİP TİTREŞİM TAKOZLARI

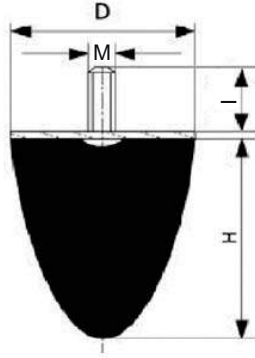

D (mm)	H (mm)	M (mm)	I (mm)
20	25	6	18
25	19	6	20
25	20	8	18
25	25	6	20
30	30	8	20
30	36	8	23
35	40	8	23
45	40	10	28
50	48	10	25
50	50	10	28
50	67	8	38
65	55	10	23
70	60	12	35
72	58	12	37
75	70	12	37
75	90	12	28

AT (MAKARA) TİP TİTREŞİM TAKOZLARI

Kod	D (mm)	T (mm)	H (mm)	M (mm)	B/B1 (mm)
İGS 0112	80	64	60	M 12	27
İGS 0212	80	64	60	M 12	27/37
İGS 0113	110	85	60	M 14	27

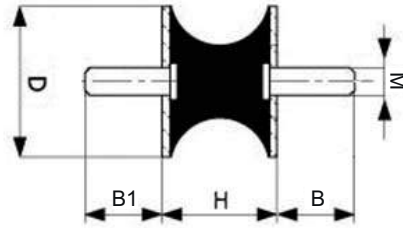

AYAK TİP KONİK TİTREŞİM TAKOZLARI

Kod	d (mm)	c (mm)	h (mm)	m (mm)	ı (mm)
İGS 0612	50	70	35	M 10	23
İGS 0124	80	108	50	M 12	27
İGS 0125	95	150	60	M 12	27
İGS 0126	95	150	105	M 12	27

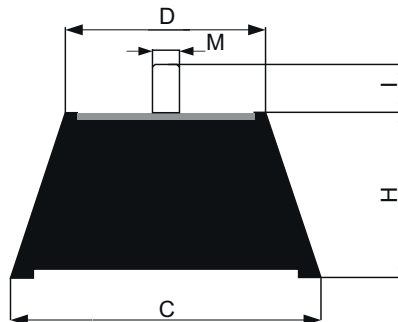

Özellikler:

EPDM sünger contalar kullanım alanları bakımından diğer süngerlere oranla daha yüksek oranda verim sağlayan ve gerek ısı aralığı gerekse malzeme dayanımı açısından oldukça yüksek değerlere sahip bir üründür. EPDM esaslı,yumuşak yapıya sahip,kapalı gözenekli süngerdir.

Toz ,Hava ve su sızdırmazlığının yanısıra sıkışabilme özelliği gerektiren özel formlu contalar, tek tarafı yapışkanlı yalıtım bantları ve benzeri sızdırmazlık ürünleridir. Yoğunlukları bakımından 4 sınıfa ayrılmaktadır. 075-100-130-170 yoğunluklarında sınıflandırılmaktadırlar.

Tek yüzeyi astar ile kaplıdır.Bu astar malzeme deformasyonunu en aza indirmek için ek bir katman vazifesi görmektedir. Türkiye'deki tek astarlı EPDM süngerler tarafımızda bulunmaktadır. Fiyat bakımından diğer vasıflı EPDM sünger contalara oranla ek takviyeli olması Otomotiv,Beyaz eşya ve yan sanayi firmaları açısından başlıca tercih sebeplerinden gelmektedir.

Yapışkan takviyesi yapışkansız,tek tarafı yapışkanlı,çift tarafı yapışkanlı olarak üretilmektedir. Kesimli şerit halinde üretimlerimizde bant olarak Ağ takviyeli Düz Transfer bant ve OPP bant takviyesi ile malemelere yapışkanlık özelliği katmaktayız. Kullanılacak olan bantın Gr/cm3 yoğunluğu için lütfen bizden bilgi alınız.



Polietilen

Neopren

EVA

EPDM

Silikon

Sert Lastik

FİLTRE SÜNGERİ

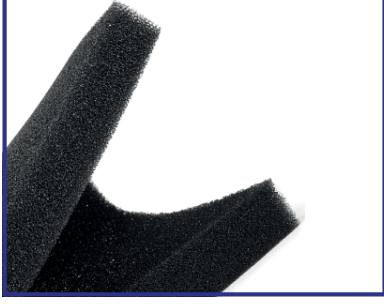

Merkezi tip havalandırma sistemlerinde, fan-coil emişlerinde ve split klimalarda ön filtre olarak kullanılmaktadır. Gözenekli poliürethan yapısı ile G2 sınıfında yıkanabilir filtrelerdir . Standart plakalar haline veya istenilen ölçülerde kesilerek panel filtrelerde ön filtre malzemesi olarak kullanılmaktadır.

SENTETİK FİLTRE SÜNGERİ



* Havalandırma cihazlarında ön filtre olarak,
* Hassas filtrelerden önce ön filtre olarak,
* Fan ve ısıtıcı ünitelerini koruyucu filtre olarak,
* Klimalarda hava kalitesini arttırmak amacıyla kullanılmaktadır.

Avantajları

- * Yüksek hava debisi, düşük basınç kaybı sağlamaktadır
- * Neme dayanıklı çerçeveden imal edilebilmektedir.
- * Zik zak yüzeyi sayesinde, yüksek toz tutma kapasitesine sahiptir.
- * Standart ve standart dışı ölçüde imaledilmektedir.

PROFİL SÜNGERLER (KAPI TOZ LASTİKLERİ)



Her türlü İhtiyaçlarda; inşaat, otomotiv, tekstil, makine, dekorasyon, elektrik, mobilya, seramik, plastik ve deri sanayi gibi çok değişik sektörlerde kullanılmaktadır. Sanayi yağlara, akaryakıt ve solventlere mukavim değildir. 100 C° üzerinde yüksek ozon ve ultraviyole mukavemeti gerektiren yerler için tavsiye edilmez.

Polimer cinsi : SBR ,Kopma min:80/cm2

Sertlik : 65+5 shore, Uzama: min %300 , Özgül ağırlık : 1,4 gr/cm3 'dür.

Kare ve daire kesitlerde olup, 3 mm.'den, 25mm. 'ye kadar ölçülerde satışa sunulmaktadır. Ayrıca aynı değerlerde olmak kaydıyla U lastiği , Rakle ve elek lastiği, Buzdolap contası gibi çeşitli standart profiller de vardır. Bunun dışında her türlü özel profil imalatı da yapılmaktadır.

D TİPİ SÜNGER FİTİL (KAPI PENCERE BANTI)



Pencereler ve kapılar için kendinden yapışkanlı, kullanımı kolay tesamoll® Profilleri. Yüksek kalitede lastik profiller neredeyse tüm hava koşullarına karşı dayanıklıdır ve takması kolaydır. %40'a varan enerji tasarrufu sağlar 3 ila 7 mm arasındaki tüm boşlukları kapatır* Havaya, UV ışınlarına ve ozona dayanıklıdır. Kendinden yapışkanlı, uzun ömürlü lastik .Dayanıklılık: 8 yılSilinerek temizlenebilir. Vidasız veya çivisiz kolayca uygulanır. Sökülmesi kolaydır -50 °C ila +60 °C sıcaklıklara dayanıklıdır



2*10	EPDM SÜNGER	Yapışkanlı
2*15	EPDM SÜNGER	Yapışkanlı
2*20	EPDM SÜNGER	Yapışkanlı
2*25	EPDM SÜNGER	Yapışkanlı
2*30	EPDM SÜNGER	Yapışkanlı
2*40	EPDM SÜNGER	Yapışkanlı
2*50	EPDM SÜNGER	Yapışkanlı
3*10	EPDM SÜNGER	Yapışkanlı
3*15	EPDM SÜNGER	Yapışkanlı
3*20	EPDM SÜNGER	Yapışkanlı
3*25	EPDM SÜNGER	Yapışkanlı
3*30	EPDM SÜNGER	Yapışkanlı
3*40	EPDM SÜNGER	Yapışkanlı
3*50	EPDM SÜNGER	Yapışkanlı
5*10	EPDM SÜNGER	Yapışkanlı
5*15	EPDM SÜNGER	Yapışkanlı
5*20	EPDM SÜNGER	Yapışkanlı
5*25	EPDM SÜNGER	Yapışkanlı
5*30	EPDM SÜNGER	Yapışkanlı
5*40	EPDM SÜNGER	Yapışkanlı
5*50	EPDM SÜNGER	Yapışkanlı
10*10	EPDM SÜNGER	Yapışkanlı
10*15	EPDM SÜNGER	Yapışkanlı
10*20	EPDM SÜNGER	Yapışkanlı
10*25	EPDM SÜNGER	Yapışkanlı
10*30	EPDM SÜNGER	Yapışkanlı
10*40	EPDM SÜNGER	Yapışkanlı
10*50	EPDM SÜNGER	Yapışkanlı
15*15	EPDM SÜNGER	Yapışkanlı
15*20	EPDM SÜNGER	Yapışkanlı
15*25	EPDM SÜNGER	Yapışkanlı
15*30	EPDM SÜNGER	Yapışkanlı
15*40	EPDM SÜNGER	Yapışkanlı
15*50	EPDM SÜNGER	Yapışkanlı
20*20	EPDM SÜNGER	Yapışkanlı
20*30	EPDM SÜNGER	Yapışkanlı
20*40	EPDM SÜNGER	Yapışkanlı
20*50	EPDM SÜNGER	Yapışkanlı

FİTİLLER VE U LASTİKLERİ BAGAJ FİTİLİ



PROFİL CONTALAR

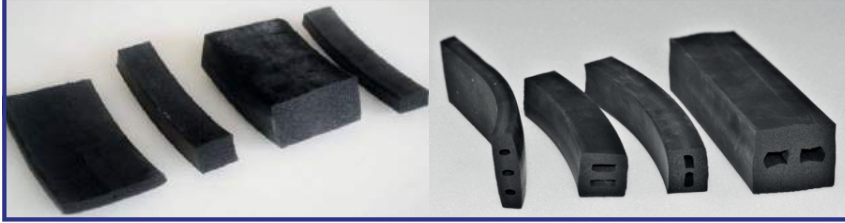

Sızdırmazlık contası olarak kullanılan sünger şeritlerin imalatı yapılmaktadır. Esnekliği arttırmak amaçlı delikli tipleri mevcuttur. Farklı ölçülerde stoklarımızda bulunmaktadır...

SACLI BALONLU FİTİLLER



U FİTİLLER



KAPI FİTİLLERİ



FİTİL GRUBU



LASTİK LEVHA



1 mm'den 20 mm'ye kadar kalınlıklarda üretilen bu levhalar, aşınmaya ve sürtünmeye karşı dayanıklıdır. Taban döşemelerinde su ve kanalizasyon boru contalarında, sızdırmazlık elemanlarında, conta gereksiniminde, yalıtım ve ızalasyon gerektiren yerlerde ve amaca uygun her yerde çok rahat olarak kullanılmaktadır. Standart üretimi 1000 mm x 10000 mm olmasına rağmen isteğe göre değişik ebatlarda da üretilmektedir.

NİTRİL LASTİK LEVHA



Nitril levha benzine ve petrole karşı dayanıklılığı çok iyidir. Normal formülasyonla 200 kg/cm²'lik basınca dayanır. %370 oranında uzama yapabilir. Sürtünmeye karşı çok iyi derecede dayanıklıdır. Kolay yırtılmaz. -15 °C ile 110 °C sıcaklık arasında rahatlıkla kullanılabilir. Bu sıcaklık özel formüllerle 160 °C'ye kadar çıkarılabilir.

KORT BEZLİ LASTİK LEVHA



Kort bezli lastik levhalar fiziksel dayanıklılığı kort bezi ile güçlendirilmiş lastik levhalardır. Kort bezli lastik levha, ağır iş makine ekipman, araç altlarında vibrasyonu önlemek ve köprü ayaklarında mesnet lastiği olarak da kullanılmaktadır. Kort bezli lastik levhalar beton santrallerinde hazne contası ve diğer contalar için de kullanılır. Kort bezli lastik levha yüksek basınç değerlerine dayanıklı olarak üretilmektedir. Kort bezli lastik levhalar aşınmaya karşı dirençli üretilir. Bu sayede yaşlanma ömrü uzundur. Kort bezli lastik levhalar yüksek esneklik ve mekanik özellik gerektiren yerlerde de kullanılır... Kort bezli lastik levhalar istenilen boy ve ölçülerde üretilmektedir...

KUMLAMA LASTİK LEVHA



Kumlama odalarında yüzey kaplama amaçlı kullanılan, mukavemeti yüksek, yumuşak bir malzemedir. Ayrıca titreşim ve gürültü yaratan makine altlarında güvenle kullanılır.

Dİ ELEKTRİK LEVHA



Pano önleri, makine önleri, trafolarında kullanılması iş güvenliği açısından yasal zorunluluk olan izole halılar 15000 volt ve 35000 volta dayanıklı olarak üretilmektedir. Kalınlığı 3mm ve 5mm dir. Eni 100cm olup boyları 10 ar metredir. Ayrıca fire vermemeniz için istediğiniz uzunluklarda kesim yapılmaktadır.

NEOPREN LASTİK LEVHA

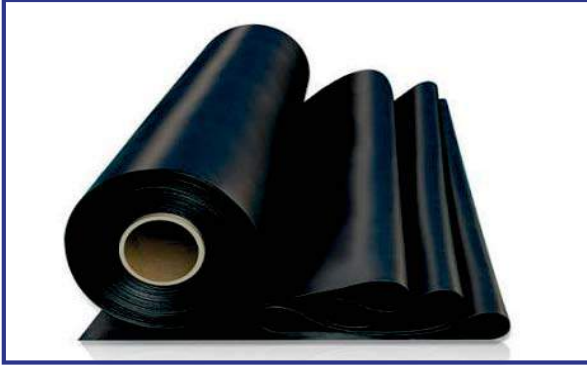

Aşınma değeri diğer levhalardan daha da azdır.
En büyük özelliği alev dayanıklı olmasıdır.
Petrol bazındaki yağlara,
güneş ışınına, ozona ve oksijene karşı dayanıklıdır.
Isı Değerleri: -50°C - + 300°C

DESENLİ LASTİK LEVHA



Otomotiv Sektöründe Araç İçi Döşeme Olarak
Endüstri Sektöründe Taşıma (Palet)tezgah Üzeri
Zemin Kaplama Malzemesi Olarak Kullanılmaktadır.
Standart Kalınlık 3mm Olarak İmal Edilmektedir.
Standart Levha Eni: 1,20 mt Boyu 10 mt'dir
Standart Renkleri: Siyah ve Gri'dir

EPDM LASTİK LEVHA

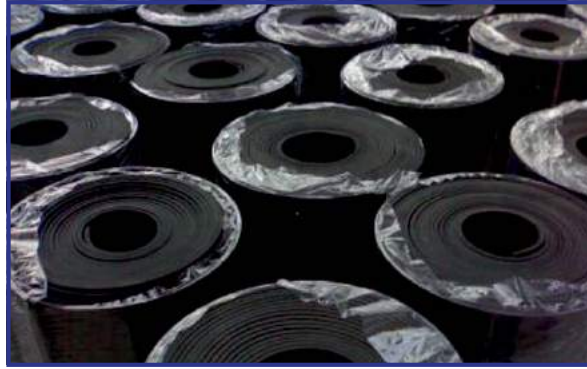

Sıcak malzemenin kullanıldığı ortamlarda
kullanılmaktadır.
-50°C ile 160°C arası dayanıklılık göstermektedir.
Asit, oksijen ve suya karşıda mukavemeti iyidir.

DON YAĞLI SALMASTRA



Sentetik katkılı pamuk ipliğinin parafin ve özel yağlar ile
emprenye edilerek 2-3 kat diagonal örgü ile kare kesit
olarak imal edilir. Gemi şaftlarında, soğuk su
motorlarında, boru bağlantı yuvalarında,
mil yuvalarında sızdırmazlık için kullanılır.

GRAFİTLİ CAM ELYAF SALMASTRA



Cam elyaf salmastra daha sonra grafit kaplama
işleminde geçirilmektedir. Grafit kaplama sürtünme
kaybını düşürür. Cam elyaf salmastra statik conta
uygulamalarında yaygın olarak kullanılır. Konteynerler,
ısıtıcılar, rögar kapakları ve boru gibi sistemlerde ısı
yalıtımı ve yangın önleme özelliklerine sahiptir.
Su, buhar, hava, yağ ve benzeri kimyasal özellikler
bakımından nötr ortamlar için uygun bir malzemedir.

SAF OMEFLON SALMASTRA (PTFE)



TANIM: Katkı maddesi ya da yağ olmayan saf lifli PTFE iplikten imal edilen katkı maddesinin olmaması salmastranın kimyasal direncini arttırmakta ve bunların arasında güçlü oksidanlar da bulunmaktadır.

UYGULAMA ALANLARI:

Rotodinamik pompalar, piston pompalar ve endüstriyel bağlantı yerleri için, yemek, kimya ve ilaç sektörü ile içme suyu arıtım tesislerinde kullanılmaktadır. Oksijen içeren tesisatlarda kullanılabilir. Su, buhar, yağlar, solventler, tuzlar ve alkaliler ile güçlü oksidanlar hariç, karşı dirençlidir.

GRAFİTLİ OMEFLON SALMASTRA



Grafit ve büyük miktarda silikon yağı ile bütünleştirilmiş lifli PTFE iplikten imal edilen salmastra, oldukça esnek ve yumuşak bir üründür. Sürtünme katsayısı düşük, ısı iletkenliği yüksektir. Salmastra her türlü endüstriyel ve ekonomi sektöründe kullanılan rotodinamik pompalar için tercih edilen bir salmastradır. Su, buhar, yağlar, sıvı yakıtlar, asit ve alkaliler gibi medyumlara karşı yüksek direnci sayesinde, kimyasal ve enerji üretim sektörlerinde kullanılmakta ve belediyelerin inşaat sektörlerinde tercih edilmektedir.

KEMPOP YAĞLI SALMASTRA



Isıya Dayanıklı ip yağlayıcı ve özel kimyasallarla emprenye edilerek 2-3 kat diagonal örgü ile kesit olarak imal edilir. Yumuşak ve esnekliği ile kullanılması kolay olan Kempop su, buhar, gazlar alkaliler, asitler, tuz çözümleri, organik kimyasallar ve yağlı ortamlarda kullanılabilir.

SAF GRAFİT SALMASTRA



Keten merkez üzerine saf ekspande grafitten imal edilmiştir. Isıl ve kimyasal direnci, kendi kendini yağlayabilmesi ve iyi ısı iletkenliği sayesinde, ekspande grafit yüksek sıcaklıklarda rotodinamik pompalar ve bağlantı yerlerinde kullanılan örne salmastralar kullanılmaktadır.

ARAMİD KEVLAR SALMASTRA



İplik üretiminde kullanılan aramid ipliğinin kullanılması ile birlikte bu salmastranın mekanik ve kimyasal faktörlere karşı yüksek sıcaklıklarda direnci garanti altına alınmaktadır. Aşındırıcı maddelerde, kum, kanalizasyon atıkları ve diğer aşındırıcı maddeler gibi, maruz kalan pompalar ve bağlantı yerleri için özellikle önerilmektedir. Bunun yanı sıra yüksek basınçlı pompalar ve bağlantı yerleri ile, su tuz çözümleri, güçlü asit ve baz medyumlarda, organik maddeler; sıvı yakıtlar, yağlar, gres ve solventler ile kullanım için önerilmektedir. Endüstri ve belediye ekonomisi ile madencilik sektörlerinde kullanılmaktadır.

EMOFLON RAMİ YAĞLI SALMASTRA



Örne sürecinde düğüm düğüm özel PTFE bazlı karışımın emdirildiği doğal ketenden örne salmastra, emdirmenin 2 kat fonksiyonu bulunmaktadır; sürtünme katsayısını düşürürken, kimyasal direnci artırır. Aynı zamanda hassas keten lifleri ortaya çıkan salmastranın istisnai biçimde yumuşak olmasını ve salmastra kutusuna iyice oturmasını sağlar. Genel amaçlı salmastra. Su, yağ, sıvı yakıtlar, kayganlaştırıcılar ve solventler, sulu tuz çözümleri ile güçlü asit ve baz medyumlara dirençlidir. Pompa ve bağlantı elemanlarında kullanılır

CAM ELYAF ÖRGÜLÜ SALMASTRA

Komple örgülü, yoğun, yüksek çekme dayanımına ve performansa sahip kare/dikdörtgen kesitli salmastralardır. Cam elyaf iplerin saç örgü şeklinde örülmesi ile genel olarak 5-100 mm arasında değişen kesitlerde üretilmektedir. Rulo boyları kesit ölçüsüne göre 25-50-100m olarak değişebilmektedir. 3 ve 4'lü çapraz örgülü olarak kare kesitli örülmektedir. Detaylı bilgi için firmamıza başvurunuz.

STANDART ÖLÇÜLERİN BİR METREDEKİ ORTALAMA AĞIRLIKLARI

Kesit mm ²	4x4	6x6	8x8	10x10	12x12	14x14	16x16	18x18	20x20	25x25	30x30
Gr. / m	25	40	70	100	140	180	270	340	450	600	850



CAM ELYAF YUVARLAK SALMASTRA

Komple örgülü, yoğun, yüksek çekme dayanımına ve performansa sahip dairesel kesitli salmastralardır. Cam elyaf ipler saç örgü şeklinde örülme ile genel olarak 5-100 mm arasında değişen kesitlerde üretilmektedir. Rulo boyları kesit ölçüsüne göre 25-50-100 m olarak değişebilmektedir.

STANDART ÖLÇÜLERİN BİR METREDEKİ ORTALAMA AĞIRLIKLARI

Çap mm	Ø 4	Ø 6	Ø 8	Ø 10	Ø 12	Ø 14	Ø 16	Ø 18	Ø 20	Ø 25	Ø 30
Gr. / m	15	24	40	60	80	110	150	190	230	350	500



SERAMİK KARE ÖRGÜLÜ SLAMSTRA

Alümina-silika malzemeden imal edilen yüksek kaliteli seramik ipliklerden 3 ve 4'lü çapraz sitilde örülmüştür. Kare kesitli bu malzeme yüksek sıcaklık dayanıklılığı ve kararlılığı, düşük termal geçirgenlik, düşük ısı depolama kapasitesi, mükemmel termal şok direnci, hafiflik ve iyi korozyon direnci özelliklerine sahiptir. İstenilen ölçüde üretilebilmektedir.

STANDART ÖLÇÜLERİN BİR METREDEKİ ORTALAMA AĞIRLIKLARI

Kesit mm ²	4x4	6x6	8x8	10x10	12x12	14x14	16x16	18x18	20x20	25x25	30x30
Gr. / m	25	40	70	100	140	180	270	320	400	600	850



SERAMİK FİTİL SALMASTRA

Alümina-silika malzemeden imal edilen yüksek kaliteli seramik ipliklerden örülmüştür. Daireselkesitli bu malzeme yüksek sıcaklık dayanıklılığı ve kararlılığı, düşük termal geçirgenlik, düşük ısı depolama kapasitesi, mükemmel termal şok direnci, hafiflik ve iyi korozyon direnci özelliklerine sahiptir. Paslanmaz çelik tel ve nikel tel takviyeli seçenekleri de mevcuttur.

STANDART ÖLÇÜLERİN BİR METREDEKİ ORTALAMA AĞIRLIKLARI

Çap mm	Ø 4	Ø 6	Ø 8	Ø 10	Ø 12	Ø 14	Ø 16	Ø 18	Ø 20	Ø 25	Ø 30
Gr. / m	15	24	40	60	80	110	150	190	230	350	500



SERAMİK VE CAM ELYAF İP

Seramik elyaf ipler, tamamen asbestsiz yapıda olup temel hammaddeleri olan seramik elyafın yüksek sıcaklık dayanım ve yalıtım özelliğini taşırlar. Bu ürünler mekanik dayanımlarının artırılması amacıyla cam elyaf, paslanmaz çelik tel veya alaşımlı teller ile güçlendirilerek 425 Tex'den 2500 Tex'e kadar tek, çift ya da üçlü sarmal haline getirilerek üretilirler. Ürün aynı zamanda diğer tüm seramik elyaf tekstil ürünlerin temel malzemesidir. Sıcaklık dayanımı 1260°C ve 1430°C olan 2 ana ürün tipi mevcuttur: Seramik Elyaf Isı Değeri 1260°C Cam Elyaf Isı Değeri 550°C

Uygulama Alanları

- Yüksek sıcaklık sızdırmazlık contası.
- Seramik elyaf tekstil üretimi.
- Yüksek sıcaklığa dayanıklı tekstil ürünlerde dikiş ipliği.



KEVLAR İP

Kevlar, çok hafif karbon kökenli çok sağlam liflerden oluşan bir malzemedir. Kevlar çok yüksek çekme gerilimine dayanabilen liflerden oluşan ipliksi bir yapıdır. Dokunabilir, kumaş haline getirilebilir, kesilebilir ve dikilebilir. Aynı ağırlıktaki çelikten 5 kat daha sağlamdır 350°C ısıya mukavemetlidir



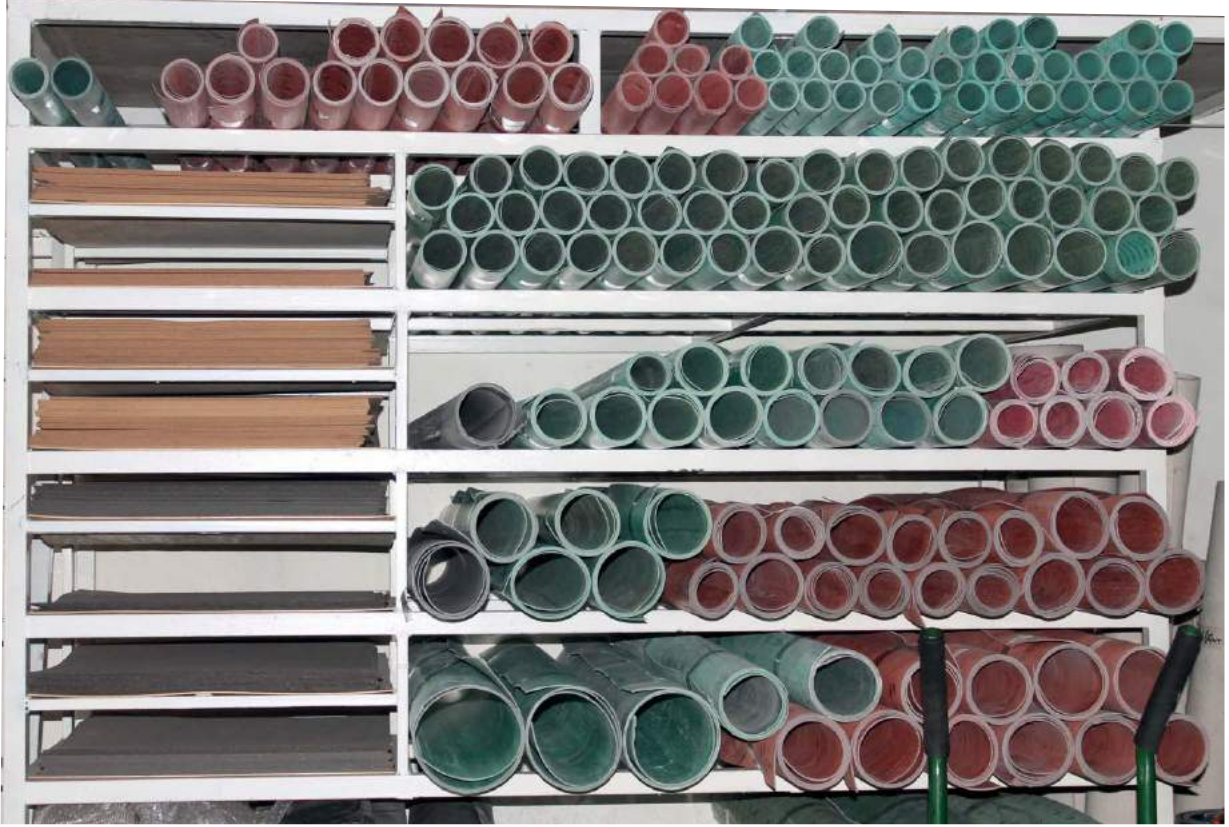

TESNİT BA 50 KLİNGRİT LEVHA

Aramid Elyaf ve NBR ile oluşmuş özel contalık malzemedir. Mükemmel kimyasal mukavemete sahiptir. Geniş bir kullanım alanı olması ile birlikte gaz yiyecik ve kimyasal sanayide sıklıkla kullanılmaktadır.

KALINLIK	ÖLÇÜ (mm)	1 PLAKA AĞIRLIK %±5
0,5	1500x1500	2.100 gr.
0,8	1500x1500	3.400 gr.
1	1500x1500	4.300 gr.
1,5	1500x1500	6.400 gr.
2	1500x1500	8.500 gr.
2,5	1500x1500	10.600 gr.
3	1500x1500	12.800 gr.
4	1500x1500	17.100 gr.
5	1500x1500	21.300 gr.

TEKNİK BİLGİLER	
Tepe Sıcaklığı	280°C
Daimi Sıcaklığı	220°C
Buharda	180°C
Basınç	80°C



TESNİT BA 203 KLİNGRİT LEVHA

Aramid Elyaf ve NBR ile oluşmuş orta derecedeki yüklemelerde su, gaz, yağ ve yakıt mukavemetine sahiptir.

KALINLIK	ÖLÇÜ (mm)	1 PLAKA AĞIRLIK %±5
0,5	1500x1500	2.100 gr.
0,8	1500x1500	3.400 gr.
1	1500x1500	4.300 gr.
1,5	1500x1500	6.400 gr.
2	1500x1500	8.500 gr.
2,5	1500x1500	10.600 gr.
3	1500x1500	12.800 gr.
4	1500x1500	17.100 gr.
5	1500x1500	21.300 gr.

TEKNİK BİLGİLER	
Tepe Sıcaklığı	250°C
Daimi Sıcaklığı	200°C
Buharda	160°C
Basınç	50°C

ASBESTSİZ KLİNGRİT LEVHA (YEŞİL)

Aramid elyaf, mineral elyaf ve sentetik NBR kompoze olmuş contalık levha. Hafif ve orta ortamlarda yağa dayanıklı contalık malzemedir. Su, gaz, yağ ve yakıtta dayanıklı ekonomik kalitede çözüm sağlar. Kolaylıkla şekil değiştirebilen komponent yapısıyla düşük yüzey basınçlı valf kapakları ve kazanlarda conta olarak kullanılabilir.

KALINLIK	ÖLÇÜ (mm)	1 PLAKA AĞIRLIK %±5
0,5	1500x1500	2.100 gr.
0,8	1500x1500	3.400 gr.
1	1500x1500	4.300 gr.
1,5	1500x1500	6.400 gr.
2	1500x1500	8.500 gr.
2,5	1500x1500	10.600 gr.
3	1500x1500	12.800 gr.
4	1500x1500	17.100 gr.
5	1500x1500	21.300 gr.

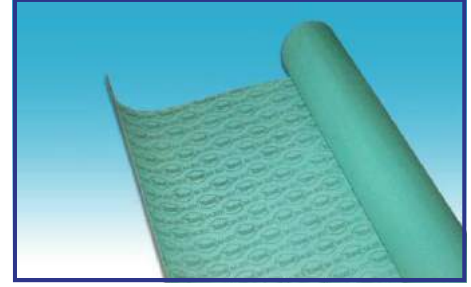

ASBESTSİZ KLİNGRİT LEVHA (SİYAH)

Aramid elyaf, mineral elyaf ve sentetik NBR kompoze olmuş contalık levha. Hafif ve orta ortamlarda yağa dayanıklı contalık malzemedir. Su, gaz, yağ ve yakıtta dayanıklı ekonomik kalitede çözüm sağlar. Kolaylıkla şekil değiştirebilen komponent yapısıyla düşük yüzey basınçlı valf kapakları ve kazanlarda conta olarak kullanılabilir.



KALINLIK	ÖLÇÜ (mm)	1 PLAKA AĞIRLIK %±5
0,5	1500x1500	2.100 gr.
0,8	1500x1500	3.400 gr.
1	1500x1500	4.300 gr.
1,5	1500x1500	6.400 gr.
2	1500x1500	8.500 gr.
2,5	1500x1500	10.600 gr.
3	1500x1500	12.800 gr.
4	1500x1500	17.100 gr.
5	1500x1500	21.300 gr.

GRAFİTLİ TELLİ KLİNGRİT LEVHA

Orta Krizotil aramid lifli özel SBR kauçuk, çeşitli kimyasal ve boya maddeleri ile vulkanizatörlerden meydana gelen hammadde kompozisyonunda ce CAS prosesiyle imal edilmiştir. Mukavemetini arttırmak üzere özel çelik örgü ile takviye edilmiştir. Orta derecedeki işletme şartlarında, sıcak ve soğuk su, buhar ve gaz devrelerinde amacıyla kullanılır.

KALINLIK	ÖLÇÜ (mm)	1 PLAKA AĞIRLIK %±5
1	1500x1500	4.300 gr.
1,5	1500x1500	6.400 gr.
2	1500x1500	8.500 gr.
2,5	1500x1500	10.600 gr.
3	1500x1500	12.800 gr.
4	1500x1500	17.100 gr.
5	1500x1500	21.300 gr.

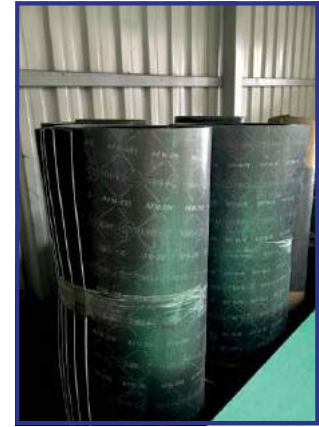

SAÇLI KLİNGRİT LEVHA

Kalay kaplı metalin çift yönlü perfore edilmesi (delinerek), selülozik esaslı ısıya ve yağa dayanıklı kağıdın yüzeylere lamine edilmesiyle imal edilir.

UYGULAMA ALANI:

. Otomotiv motorlarının silindir kapak contaları
. Egzost contaları, Manifold contaları imalatında kullanılır.

TEKNİK BİLGİLER		
Kalınlık	Ebat	Renk
1mm. - 2.2mm.	500mm. x 40 mm.	Gri - Siyah

KAUÇUK YAPRAK



Yaprak kauçuk levha conta yapımında esnek bir malzemedir. Levhaların sızdırmazlık özelliği vardır, kolay işlenebilirlik, esneklik, düşük kalıcı deformasyon ve yayılma özelliklerine sahip bir üründür...

Yaprak kauçuk levha istenilen boy ve ölçülerde imal edilmektedir...

PU SIYIRICI



Pozisyonu tahrik tamburunun ön kısmıdır. Her tür uygulamada, her malzemede kullanılabilir. Poliüretan bıçaklar esnek ve aşınmaya mukavimdir. Mekanik ekle eklenmiş bantlara uyumludur. Montajı ve yedek parça değişimi çok kolaydır. Yedek parçaları uygun fiyatlıdır ve kolay temin edilir.

POLİÜRATAN LEVHA



Aşınmaya karşı yüksek dirençleri, yüksek kopma ve yırtılma mukavemetleri, kopma uzamaları. Ozona, dış hava koşullarına, ultraviyole ışınlarına, yağ ve kimyasallara karşı dayanımları gibi üstün özellikleri ile poliüretan elastomerler birçok özel amaçlı kullanıma sahiptir.

SIYIRICI BANTLAR (SİLGİ LASTİĞİ)



Sıyırıcılar, konveyör hattında taşınan materyalleri konveyör bantın üzerine doğru yönlendirmekte ve materyalin hattın dışına çıkmasını önlemekte kullanılırlar. Silgi lastiği olarakta kullanılır.

PVC ŞEFFAF MİKA

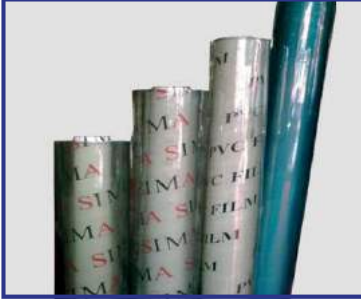

Genel olarak kış bahçesi, çanta, ayakkabı, Soğuk oda kapısı fabrika kapıları vb... uygulamalarında kullanılan malzeme % 100 PVC den oluşmaktadır. Cam kadar saydam ve düz bir satıha sahiptir. 1 mm - 5 mm ye kadar bulunmaktadır.

PVC YER DÖŞEMESİ



Çevre koşullarından gelecek zararlı etkilere ve aşınmalara dayanıklıdır. Son derece hijyeniktir, üzerinde bakteri barındırmaz. Zengin renk ve model seçimine sahiptir. Uygulaması kolay ve hızlı, temizliği pratik ve ekonomiktir. Çevrecidir, yeniden işlenebilir ve yeni zemin kaplamalarının üretiminde kullanılabilir.

KAUÇUK ARAÇ DÖŞEMESİ



Araç içi döşemelerde, bina, site, bahçe vb. alanlar için uygundur. İthal koku yapmaz. Farklı Renk ve desen seçenekleri ile 120 cm ve 140 cm ne ve 10 mt uzunluklarda mevcuttur.

BAKLAVA DESENLİ KASA DÖŞEMESİ



Kapalı ve açık kamyon kasalarında zemini korumak amaçlı mukavemeti yüksek bezli ve telli kauçuk levhalardır.
En:180 cm ve 214 cm Boy:10 mt dir.

RULO MANTAR LEVHA

Mantar levhalar ve mantar rulolar inşaat / marin sektörlerinde ses, ısı, vibrasyon ve titreşim absorblama amaçlı olarak geniş bir kullanım alanına sahiptir. Mantar şilteler ayrıca zemin altı, parke altı, şap altı uygulamalarında ses, ısı ve darbe emici özelliği sayesinde mükemmel bir yalıtım sağlar. Mantar ürünleri doğaldır ve içeriğinde kanserojen maddeler bulunmamaktadır. Kullanım alanları arasında; Laminat Parke, Lamine Parke, Masif Parke, Linolyum, Marmolyum, Vinil, PVC Yer Döşeme Sistemlerinde, Halı, Seramik, Mermer, Granit ve Doğal Taş zeminlerin altında ve yerden ısıtma sistemlerinde kolay ve pratik yalıtım çözümleri sağlar. Ayrıca, mantar ürünleri, iç mantolamada ve komşu duvarlarda ses & ısı yalıtımı amaçlı doğal çözümler sağlar. Kullanım yerine göre, doğal mantar ürünleri kalınlık ve yoğunluklarında değişiklik göstermektedir. Tavsiye edilen kalınlık ve yoğunluk ile ilgili detaylı bilgiyi firmamız ile temasa geçerek öğrenebilirsiniz.



MANTAR LEVHA (NORMAL)

Her türlü araç ve iş makinelerinin karter kapak, silindir üst kapak ve diğer conta ve sızdırmazlık ihtiyaçlarını karşılamaktadır.

Yüksek kalitede mantar granül ham maddeleri birleştirilerek bloklar halinde üretilir.

Özel isteklere göre mantar granül ebadı, ürün rengi, ürün sertliği ve ürün yoğunluğu ayarlanabilir.

Üretilen bloklar istenilen kalınlık ve ebatlarda dilimlenir. Sektörün istek ve talepleri doğrultusunda levha veya hazır conta olarak üretilebilmektedir.

Her türlü conta ve sızdırmazlık ihtiyaçlarınız için, iletişim adreslerimizden bize ulaşabilirsiniz.

MANTAR LEVHA KAUCUKLU

Her türlü araç ve iş makinelerinin karter kapak, silindir üst kapak ve diğer conta ve sızdırmazlık ihtiyaçlarını karşılamaktadır.

Yüksek kalitede mantar granül ve nitril kauçuk ham maddeleri birleştirilerek bloklar halinde üretilir.

Özel isteklere göre mantar granül ebadı, ürün rengi, ürün sertliği ve ürün yoğunluğu ayarlanabilir.

Üretilen bloklar istenilen kalınlık ve ebatlarda dilimlenir. Sektörün istek ve talepleri doğrultusunda levha veya hazır conta olarak üretilebilmektedir.

Her türlü conta ve sızdırmazlık ihtiyaçlarınız için, iletişim adreslerimizden bize ulaşabilirsiniz.



PTFE KUMAŞ YAPIŞKANLI(TEFLON KUMAŞ)

Yapışkanlı PTFE bantların üretiminde 270°C -300°C ısıya dayanıklı özel silikon bazlı yapıştırıcılar kullanılır. PTFE kaplı cam elyaf kumaşlar bu sayede yüksek ısılarda bile yapışkan özelliklerini kaybetmezler. PTFE bantlar genel olarak gıda sektöründe her türlü yiyecek kurutma ve pişirme fırınlarında ,ambalaj sanayinde ,poşet ağzı yapıştırma makinelerinde ,laminasyon işlemlerinde, kauçuk preslerinde mobilya sektöründe ve tekstil sektöründe başarı ile kullanılmaktadır



PTFE KUMAŞ YAPIŞKANSIZ(TEFLON KUMAŞ)



PTFE bantların üretiminde 270°C-300°C ısıya dayanıklı özel silikon bazlı yapıştırıcılar kullanılır. PTFE kaplı cam elyaf kumaşlar bu sayede yüksek ısılarda özelliklerini kaybetmezler. PTFE bantlar genel olarak gıda sektöründe her türlü yiyecek kurutma ve pişirme fırınlarında ,ambalaj sanayinde ,poşet ağzı yapıştırma makinelerinde ,laminasyon işlemlerinde, kauçuk preslerinde mobilya sektöründe ve tekstil sektöründe başarı ile kullanılmaktadır



PRESLİ YÜN KEÇELER

Tamamen yün veya diğer sentetik fiberlerin kombinasyonu ile oluşan liflerin birbirleriyle birleştirilerek üretilen pek fazla kullanım alanına sahip bir malzemedir.

Yüzde yüz yünden yapılmış bu malzemenin sayısız kullanım alanı olup bunların bazıları şunlardır ;

- Yağ, hava ve sıvı filtrelerinde
 - Yağ ve gres sızdırmazlığında
 - Yağlama fitili olarak
 - Yer parlatıcıları olarak
 - Toz toplama ve yalıtımında
 - Yer parlatıcıları olarak
 - Endüstriyel eldiven imalatında
 - Ambalajlamada
 - Baskı silindirlerinde
 - Parlatma ve cilalamada
 - Şerit metal silicileri olarak
 - Pencere kanal salmastrası olarak
- Kalınlıklar: 2 mm - 30 mm arası**

DÜZ REKOR 	DÖNER DİRSEK 	HIZ AYARLI DİRSEK 	DIŞLI YE 	ORTA BACAK TE 
YAN BACAK TE 	TE 	DÜŞÜRÜCÜ TE 	NİPEL 	DÜŞÜRÜCÜ NİPEL 
KURUVA 	YE 	DÜŞÜRÜCÜ YE 	DİRSEK 	DÜŞÜRÜCÜ DİRSEK 
DÜŞÜRÜCÜ 	PERDE GEÇİŞ NİPELİ 	HIZ AYAR 	DIŞI DÜZ REKOR 	DIŞI DÖNER DİRSEK 
DIŞLI MANİFOLD 	MANİFOLD 	UZUN DİRSEK 	ÇEKİLİ DÜZ REKOR 	ÇEKİLİ DÖNER DİRSEK 
ÇEKİLİ NİPEL 	ÇEKİLİ HIZ AYAR 	DIŞI PERDE GEÇİŞ NİPELİ 	45 DİRSEK 	İKİLİ DAĞITICI 
ÜÇLÜ DAĞITICI 	DÖRTLÜ DAĞITICI 	ALTI Lİ DAĞITICI 	İKİLİ DİK DAĞITICI 	KÖRLEYİCİ (KÖRTAPA) 
MİNİ DÜZ REKOR 	MİNİ DÖNER DİRSEK 	MİNİ NİPEL 	MİNİ TE 	MİNİ DIŞLI TE 
YAYLI SUSTURUCU 	SİNTER SUSTURUCU 	KISA SİNTER 	PLASTİK SUSTURUCU 	VANA 

TEK BOBİN VALFLER



- 1/8-32 TEK BOBİN VALF N.K
- 1/4-32 TEK BOBİN VALF
- 3/8-32 TEK BOBİN VALF
- 1/8-52 TEK BPOBİN VALF
- 1/4-52 TEK BOBİN VALF
- 3/8-52 TEK BOBİN VALF
- 1/2-52 TEK BOBİN VALF

ISO VALFLER



- ISO1-5/2 TEK BOBİN VALF
- ISO1-5/2 ÇİFT BOBİN VALF
- ISO2-5/2 TEK BOBİN VALF
- ISO2-5/2 ÇİFT BOBİN VALF
- ISO3-5/2 TEK BOBİN VALF
- ISO-5/2 ÇİFT BOBİN VALF

MAKARALI VALFLER



- 1/8-32 MAKARALI VALF
- 1/4-32 MAKARALI VALF

ÇİFT BOBİN VALFLER



- 1/8-52 ÇİFT BOBİN VALF
- 1/4-52 ÇİFT BOBİN VALF
- 1/4-53 ÇİFT BOBİN K/M VALF

HAVA UYARILI VALFLER



- 1/8-32 HAVA - YAY N.K
- 1/8-52 HAVA YAY
- 1/8-52 HAVA - HAVA
- 1/4-32 HAVA-YAY (pilot basınçlı)
- 1/4-52 HAVA - YAY (pilot basınçlı)
- 1/4-52 HAVA - HAVA



- 1/4-52 KOL - YAY VALF
- 1/4-52 KOL - KOL VALF
- 3/8-52 KOL - YAY VALF
- 3/8-52 KOL - KOL VALF



YASTIKLI PNÖMATİK SİLİNDİR



ALUMİNYUM PROFİL PNÖMATİK SİLİNDİR



ALUMİNYUM PROFİL MANYETİK YASTIKLI



PNÖMATİK-SİLİNDİR



SHORT-STROK-(JİG) SİLİNDİR



MANYETİK YATAKLI BLOG SİLİNDİR



MANYETİK KOMPAKT SİLİNDİR



TABLALI JİG SİLİNDİR



PASLANMAZ GÖVDE KALEM SİLİNDİR



ÇİFT MİLLİ MANYETİK İKİZ SİLİNDİR



ÇATAL BAĞLANTI (SEGMANLI)



AYAK BAĞLANTI



FİLANŞ BAĞLANTI



KLİPSLİ ÇATAL BAĞLANTI



EKLEM BAĞLANTI



EKLEM YER BAĞLANTISI



YER BAĞLANTI





**AKARYAKIT
HORTUMLARI**



**AŞINDIRICI MADDE
HORTUMLARI**

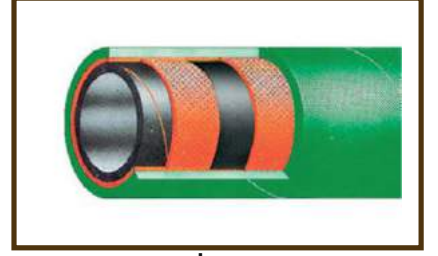

**KİMYA
HORTUMLARI**



**SICAK SU BUHAR
HORTUMLARI**



**GIDA
HORTUMLARI**



**HİDROLİK
HORTUMLARI**



**KAUÇUK BEZLİ
HORTUMLAR**

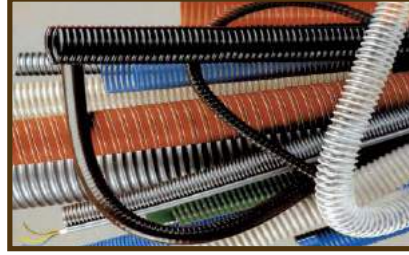

**ENDÜSTRİYEL
HORTUMLAR**

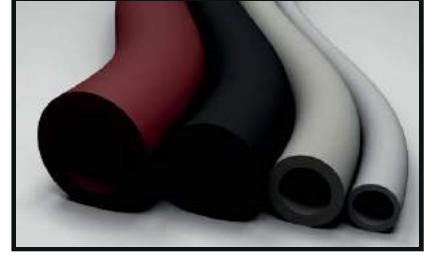

**SİLİKON
HORTUMLAR**



**PVC
HORTUM**



**HAVA
HORTUMLARI**



**SU
HORTUMLARI**

026 SERİSİ DIŞ BAĞLANTILI ERKEK GÖVDE KAPLİN

ÇAP	UÇ GİRİŞ	BOY	BAĞLANTI	SW	KOD
D-24	D1-12	L-43	A-1/2	21	S026EG-1/2
D-24	D1-12	L-43	A-3/8	21	S026EG-3/8
	D1-12	L-43	A-1/4	21	S026EG-1/4



026 SERİSİ DIŞ BAĞLANTILI DIŞI GÖVDE KAPLİN

ÇAP	UÇ GİRİŞ	BOY	BAĞLANTI	SW	KOD
D-24	D1-12	L-47	A-1/2	24	S026DG-1/2
D-24	D1-12	L-45	A-3/8	21	S026DG-3/8
D-24	D1-12	L-43	A-1/4	21	S026DG-1/4

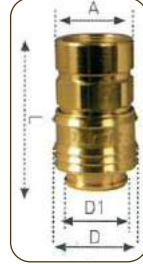

026 SERİSİ HORTUM GİRİŞLİ KAPLİN

ÇAP	UÇ GİRİŞ	BOY	SW	HRT GRŞ	KOD
D-24	D1-12	L-53	20	H-6	S026HG-6M
D-24	D1-12	L-53	20	H-8	S026HG-8M
D-24	D1-12	L-53	20	H-10	S026HG-10M
D-24	D1-12	L-53	20	H-13	S026HG-13M



026 SERİSİ PANO BAĞLANTILI HORTUM GİRİŞLİ KAPLİN

ÇAP	UÇ GİRİŞ	BOY	BAĞLANTI	SW	HRT GRŞ	KOD
D-24	D1-12	L-59	A-16*1	20	H-6	S026PHG-6M
D-24	D1-12	L-59	A-16*1	20	H-8	S026PHG-8M
D-24	D1-12	L-59	A-16*1	20	H-10	S026PHG-10M
D-24	D1-12	L-59	A-16*1	20	H-13	S026PHG-13M



026 SERİSİ HORTUM UÇ

KAPLİN GİRİŞ	BOY	HRT GRŞ	KOD
D1-12	L-43	H-6	S026HUC-6M
D1-12	L-43	H-8	S026HUC-8M
D1-12	L-43	H-10	S026HUC-10M
D1-12	L-43	H-13	S026HUC-13M



026 SERİSİ ERKEK UÇ

KAPLİN GİRİŞ	BOY	BAĞLANTI	SW	KOD
D1-12	L-34	A-1/2	21	S026EUC-1/2
D1-12	L-33	A-3/8	19	S026EUC-3/8
D1-12	L-32	A-1/4	17	S026EUC-1/4



026 SERİSİ DIŞI UÇ

KAPLİN GİRİŞ	BOY	BAĞLANTI	SW	KOD
D1-12	L-35	A-1/2	24	S026DUC-1/2
D1-12	L-34	A-3/8	21	S026DUC-3/8
D1-12	L-32	A-1/4	17	S026DUC-1/4



Teknik Özellikler

Çalışma Sıcaklığı

-20 C +100 C (-4 F + 212 F)

Çalışma Basıncı

0 - 35 bar (0 - 500 PSI)

Akış Kapasitesi

NW - 8

Debi (hava için) 1000 litre/ dakika hava

Debi (su için) 18 litre/ dakika su

Standart Ürün

Pirinç

Nbr

Standart Dışı

Krom Kaplama

Viton Conta

Nikel Kaplama

Malzeme

Gövde : Pirinç

Kapak : Pirinç

Çek Valf : Pirinç

Yaylar : Paslanmaz Çelik

AISI 303+316L

Misket : Paslanmaz Çelik 316L

Conta : Buna

Uç : Pirinç

Kullanım Alanları

Pnömatik Sistem Bağlantılarında

Sıcak ve Soğuk Su Sistem

Bağlantılarında

Hidrolik Bağlantılarında

Gaz Bağlantılarında

Kimyasal Sıvı Bağlantılarında

021 SERİSİ PANO BAĞLANTILI HORTUM GİRİŞLİ KAPLİN

ÇAP	UÇ GİRİŞ	BOY	BAĞLANTI	SW	HRT GRŞ	KOD
D-16	D1-9	L-57	A-12*1	14	H-4	S021PHG-4M
D-16	D1-9	L-57	A-12*1	14	H-6	S021PHG-6M
D-16	D1-9	L-57	A-12*1	14	H-8	S021PHG-8M
D-16	D1-9	L-57	A-12*1	14	H-10	S021PHG-10M

021 SERİSİ DIŞ BAĞLANTILI ERKEK GÖVDE KAPLİN

ÇAP	UÇ GİRİŞ	BOY	BAĞLANTI	SW	KOD
D-16	D1-9	L-38	A-1/8	14	S021EG-1/8
D-16	D1-9	L-39	A-1/4	14	S021EG-1/4
D-16	D1-9	L-40	A-3/8	17	S021EG-3/8

021 SERİSİ DIŞ BAĞLANTILI DIŞI GÖVDE KAPLİN

ÇAP	UÇ GİRİŞ	BOY	BAĞLANTI	SW	KOD
D-16	D1-9	L-38	A-1/8	14	S021DG-1/8
D-16	D1-9	L-39	A-1/4	17	S021DG-1/4
D-16	D1-9	L-40	A-3/8	19	S021DG-3/8

021 SERİSİ HORTUM GİRİŞLİ KAPLİN

ÇAP	UÇ GİRİŞ	BOY	SW	HRT GRŞ	KOD
D-16	D1-9	L-47	14	H-4	S021HG-4M
D-16	D1-9	L-47	14	H-6	S021HG-6M
D-16	D1-9	L-47	14	H-8	S021HG-8M
D-16	D1-9	L-47	14	H-10	S021HG-10M

021 SERİSİ HORTUM GİRİŞLİ KAPLİN

KAPLİN GİRİŞ	BOY	HRT GRŞ	KOD
D1-9	L-32	H-4	S021HUC-4M
D1-9	L-32	H-6	S021HUC-6M
D1-9	L-32	H-8	S021HUC-8M
D1-9	L-32	H-10	S021HUC-10M

021 SERİSİ ERKEK UÇ

KAPLİN GİRİŞ	BOY	BAĞLANTI	SW	KOD
D1-9	L-27	A-1/8	12	S021EUC-1/8
D1-9	L-27	A-1/4	14	S021EUC-1/4
D1-9	L-27	A-3/8	17	S021EUC-3/8

021 SERİSİ ERKEK UÇ

KAPLİN GİRİŞ	BOY	BAĞLANTI	SW	KOD
D1-9	L-27	A-1/8	13	S021DUC-1/8
D1-9	L-27	A-1/4	16	S021DUC-1/4
D1-9	L-27	A-3/8	19	S021DUC-3/8



Teknik Özellikler

Çalışma Sıcaklığı

-20 C +100 C (-4 F + 212 F)

Çalışma Basıncı

0 - 35 bar (0 - 500 PSI)

Akış Kapasitesi

NW - 8

Debi (hava için) 1000 litre/ dakika hava

Debi (su için) 18 litre/ dakika su

Standart Ürün

Pirinç

Nbr

Standart Dışı

Krom Kaplama

Viton Conta

Nikel Kaplama

Paslanmaz Çelik

Malzeme

Gövde : Pirinç

Kapak : Pirinç

Çek Valf : Pirinç

Yaylar : Paslanmaz Çelik

AIŞI 303+316L

Misket : Paslanmaz Çelik 316L

Conta : NBR

Uç : Pirinç

Kullanım Alanları

Su Soğutmalı Sistemlerde

Kıya Sanayiinde

Yüksek Debili Gaz ve Sıvılar

Medikal Sektöründe

Hidrolik ve Pnömatik Sistemlerde



İGS-1001



S VALVE Ø 80

İGS-1002



SWINGING
SHAFT Ø 80

İGS-1003



NUT

İGS-1004



SLEWING
LEVER Ø 80

İGS-1005



WASHER

İGS-1006



SAFETY
PLATE

İGS-1007



S VALVE Ø 90

İGS-1008



SLEWING
LEVER Ø 90

İGS-1009



SWINGING SHAFT

İGS-1010



BALL CUP

İGS-1011



PLUNGER
CYLINDER Ø 60

İGS-1012



LUNGER CYLINDER
TUBE Ø 60

<p>iGS-1013</p> 	<p>iGS-1014</p> 	<p>iGS-1015</p> 	<p>iGS-1016</p> 
<p>CYLINDER LUNGER Ø 60</p>	<p>PLUNGER CYLINDER Ø 60</p>	<p>SEAL SET Ø 60</p>	<p>PLUNGER CYLINDER Ø 80</p>

<p>iGS-1017</p> 	<p>iGS-1018</p> 	<p>iGS-1019</p> 	<p>iGS-1020</p> 
<p>PLUNGER CYLINDER TUBE Ø 80</p>	<p>PISTON ROD Ø 80</p>	<p>PISTON ROD Ø 60</p>	<p>SEAL SET Ø 80</p>

<p>iGS-1021</p> 	<p>iGS-1022</p> 	<p>iGS-1023</p> 	<p>iGS-1024</p> 
<p>PLUNGER CYLINDER 160 x 80</p>	<p>PLUNGER TUBE 160 x 80</p>	<p>PLUNGER CYLINDER 200 x 80</p>	<p>LUNGER CYLINDER TUBE Ø 60</p>

<p>İGS-1024</p> 	<p>İGS-1025</p> 	<p>İGS-1026</p> 	<p>İGS-1027</p> 
<p>COMPLETE UPPER HOUSING Ø80</p>	<p>SUPPORT FLANGE Ø80</p>	<p>WEAR SLEEVE Ø80</p>	<p>DISC</p>

<p>İGS-1028</p> 	<p>İGS-1029</p> 	<p>İGS-1030</p> 	<p>İGS-1031</p> 
<p>SEAL SET Ø80 FOR UPPER HOUSING</p>	<p>COMPLETE UPPER HOUSING Ø80</p>	<p>WEAR SLEEVE Ø90</p>	<p>SUPPORT FLANGE Ø90</p>

<p>İGS-1032</p> 	<p>İGS-1033</p> 	<p>İGS-1033</p> 	<p>İGS-1034</p> 
<p>SEAL SET Ø90 FOR UPPER HOUSING</p>	<p>SUPPORT FLANGE Ø90</p>	<p>COMPLETE UPPER HOUSING Ø90</p>	<p>WEAR SLEEVE Ø90</p>

İGS-1035



SEAL SET Ø90 FOR
UPPER HOUSING

İGS-1036



DISC

İGS-1037



BUSHING

İGS-1038



COMPLETE DISCHARGE
SUPPORT

İGS-1039



DISCHARGE
SUPPORT

İGS-1040



SEAL SET FOR DISCHARGE
SUPPORT

İGS-1041

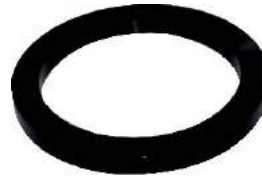

PRESSURE RING

İGS-1042



WEAR SLEEVE

İGS-1043



BEARING FLANGE
Ø60

İGS-1044



BUSH

İGS-1045



BEARING FLANGE

İGS-1046



RUBBER SEAL
Ø60

<p>İGS-1047</p> 	<p>İGS-1048</p> 	<p>İGS-1049</p> 	<p>İGS-1050</p> 
<p>O RING</p>	<p>MIXER SHAFT</p>	<p>BEARING FLANGE Ø50</p>	<p>RUBBERSEAL Ø50</p>

<p>İGS-1051</p> 	<p>İGS-1052</p> 	<p>İGS-1053</p> 	<p>İGS-1054</p> 
<p>BEARING FLANGE</p>	<p>RUBBER SEAL Ø40</p>	<p>BUSH</p>	<p>HYDRAULIC MOTOR</p>

PUTZMAISTER

<p>İGS-1055</p> 	<p>İGS-1056</p> 	<p>İGS-1057</p> 	<p>İGS-1058</p> 
<p>SEAL SET</p>	<p>MIXER SHAFT MIDDLE</p>	<p>MIXING PADDLE LEFT</p>	<p>MIXING PADDLE RIGHT</p>

İGS-1059



RUBBER BUFFER

İGS-1060



RUBBER BUFFER

İGS-1061



**RUBBER BUFFER
50X30**

İGS-1062



COMPLETE SET

İGS-1063



WEDGE

İGS-1064



MOUNTING BOLT

İGS-1065



BOLT

İGS-1066



SLIDE

İGS-1067



SEAL FOR SLIDE

İGS-1068



**SPECTACLE WEAR
PLATE**

İGS-1069



WEAR RING

İGS-1070



THRUST RING

İGS-1071	İGS-1072	İGS-1073	İGS-1074
			
SPECTACLE WEAR PLATE	WEAR RING	THRUSTRING	TORQUE SUPPORT

İGS-1075	İGS-1076	İGS-1077	İGS-1078
			
PRESSURE PLATE	WEAR STRIP	WEAR PLATE	SPECTACLE WEAR PLATE

İGS-1079	İGS-1080	İGS-1081	İGS-1082
			
INTERMEDIATE RING	DELIVERY CYLINDER 200 x 219 x 1586	200 x 219 x 2284	DELIVERY CYLINDER 230 x 254 x 1600

İGS-1083



DELIVERY CYLINDER
230 X 254 X 2320

İGS-1084



DELIVERY CYLINDER
250 x 273 x 2310

İGS-1085



PISTON RAM
200mm

İGS-1086



PISTON RAM
230mm

İGS-1087



SWITCH FORK

İGS-1088



SLIDING CLUTCH

İGS-1089



FLANGE

İGS-1090



**HOSE SINGLE &
DOUBLE FLANGE**

İGS-1091



SEAL SET
80 x 100 x 40 mm

İGS-1092



PISTON BENCH
230 MM

İGS-1093



GUIDE RING 230MM

İGS-1094



**DELIVERY PISTON
SEAL 230MM**

İGS-1095



FILTER

İGS-1096



FILTER

İGS-1097



SWITCHING
CYLINDER

İGS-1098



PISTON

İGS-1099



BLADDER 4LT

İGS-1100



ACCUMULATOR 4LT

İGS-1101



BLADDER 6LT

İGS-1102



ACCUMULATOR 6LT

PUTZMAISTER

İGS-1103



CARRYING BELT



<p>İGS-1104</p> 	<p>İGS-1105</p> 	<p>İGS-1106</p> 	<p>İGS-1107</p> 
<p>HYDRAULIC CYLINDER</p>	<p>JOINT HEAD</p>	<p>REDUCTION ELBOW</p>	<p>6" ELBOW</p>

<p>İGS-1108</p> 	<p>İGS-1109</p> 	<p>İGS-1110</p> 	<p>İGS-1111</p> 
<p>6" CLAMP COUPLING</p>	<p>6" CLAMP COUPLING</p>	<p>SEALING COVER</p>	<p>TRUNK COVER COUPLING</p>

PUTZMAISTER

<p>İGS-1112</p> 	<p>İGS-1113</p> 	<p>İGS-1114</p> 	<p>İGS-1115</p> 
<p>5.5" 45 DEGREE ELBOW</p>	<p>5.5" 90 DEGREE ELBOW</p>	<p>5.5" 90 DEGREE LAMINATED ELBOW</p>	<p>5.5" 90 DEGREE R1000</p>

<p>İGS-1116</p> 	<p>İGS-1117</p> 	<p>İGS-1118</p> 	<p>İGS-1119</p> 
<p>S-PIPE</p>	<p>5.5" 45 DEGREE ELBOW</p>	<p>5.5" 30 DEGREE ELBOW</p>	<p>5.5"20 DEGREE ELBOW</p>

<p>İGS-1120</p> 	<p>İGS-1121</p> 	<p>İGS-1122</p> 	<p>İGS-1123</p> 
<p>5.5" 15 DEGREE ELBOW</p>	<p>5.5" 10 DEGREE ELBOW</p>	<p>5.5" 90 DEGREE DELIVERY PIPE</p>	<p>REDUCER PIPE 1200 mm</p>

<p>İGS-1124</p> 	<p>İGS-1125</p> 	<p>İGS-1126</p> 
<p>REDUCER PIPE 200mm</p>	<p>5.5" 45 DEGREE DOUBLE WALLED ELBOW</p>	<p>5.5" 90DEGREE DOUBLE WALLED ELBOW</p>



PUTZMAISTER

İGS-1127



TIGHTENING STRAP

İGS-1128



CLAMP

İGS-1129



CLAMP

İGS-1130



TUBE SUPPORT

PUTZMAISTER

İGS-1131



CLAMP

İGS-1132



5.5" CLAMP COUPLING

İGS-1133



5.5" MOUNTING COUPLING

İGS-1134



5.5" COUPLING

İGS-1135



5.5" ALIAN COUPLING

İGS-1136



5.5" ALIAN COUPLING

İGS-1137







5.5" FLANGE

İGS-1138







5.5" FLANGE

İGS-1139 	İGS-1140 	İGS-1141 	İGS-1142 
5.5" FLANGE	3"-3,5"-4"-4,5"-5"-5,5"-6" RUBBER	5.5" DELIVERY TUBE 3000mm	CLEANING BALLS

İGS-1143 	İGS-1144 	İGS-1145 
CLAMP	SUPPORT PLATE 60 x 60 x 6mm	SUPPORT PLATE 50 x 50 x 6mm



<p>İGS-2001</p> 	<p>İGS-2002</p> 	<p>İGS-2003</p> 	<p>İGS-2004</p> 
<p>ROCK VALVE DN210-180</p>	<p>ROCK VALVE DN220-180</p>	<p>SLEWING SHAFT SHORT</p>	<p>SLEWING SHAFT</p>

<p>İGS-2005</p> 	<p>İGS-2006</p> 	<p>İGS-2007</p> 	<p>İGS-2008</p> 
<p>BOLT</p>	<p>KIDNEY SEALING DN180</p>	<p>PRESSURE SPRING DN210</p>	<p>BEARING BUSH</p>

SCHWING

<p>İGS-2009</p> 	<p>İGS-2010</p> 	<p>İGS-2011</p> 	<p>İGS-2012</p> 
<p>BEARING BUSH</p>	<p>TENSION NUT</p>	<p>SETTING DISC</p>	<p>SEALING COVER</p>

İGS-2013



SLEWING LEVER

İGS-2014



SEALING COVER

İGS-2015



PIN

İGS-2016



COVER

İGS-2017



SLEWING PIVOT

İGS-2018



SLEWING PIVOT

İGS-2019



BUSHING

İGS-2020



BOLT

İGS-2021



BUSHING SPLIT

İGS-2022



CLAMP

İGS-2023



SLEWING CYLINDER

İGS-2024



SLEWING CYLINDER

İGS-2025



CYLINDER HEAD

İGS-2026



CYLINDER HEAD

İGS-2027



PROTECTING TUBE

İGS-2028



TENSION RING

İGS-2029



CYLINDER SUPPORT

İGS-2030



ROD EYE

İGS-2031



CYLINDER TUBE

İGS-2032



PISTON ROD

İGS-2033



SEAL SET



<p>İGS-2034</p> 	<p>İGS-2035</p> 	<p>İGS-2036</p> 	<p>İGS-2037</p> 
<p>HOUSING LINING</p>	<p>WEARING INSERT DN200</p>	<p>WEARING INSERT DN230</p>	<p>WEARING INSERT DN250</p>

<p>İGS-2038</p> 	<p>İGS-2039</p> 	<p>İGS-2040</p> 	<p>İGS-2041</p> 
<p>BASE PLATE</p>	<p>CUTTING RING DN210</p>	<p>CUTTING RING DN220</p>	<p>PUMI WEARING INSERT DN150</p>

<p>İGS-2042</p> 	<p>İGS-2043</p> 	<p>İGS-2044</p> 	<p>İGS-2045</p> 
<p>PUMI WEARING INSERT DN160</p>	<p>CLOSURE DN250</p>	<p>SEALING RING</p>	<p>CLAMPING PIECE LEFT</p>

İGS-2046



CLAMPING PIECE RIGHT

İGS-2047



SEALING DN250

İGS-2048



**TRANSITION PIECE
DN200**



İGS-2049

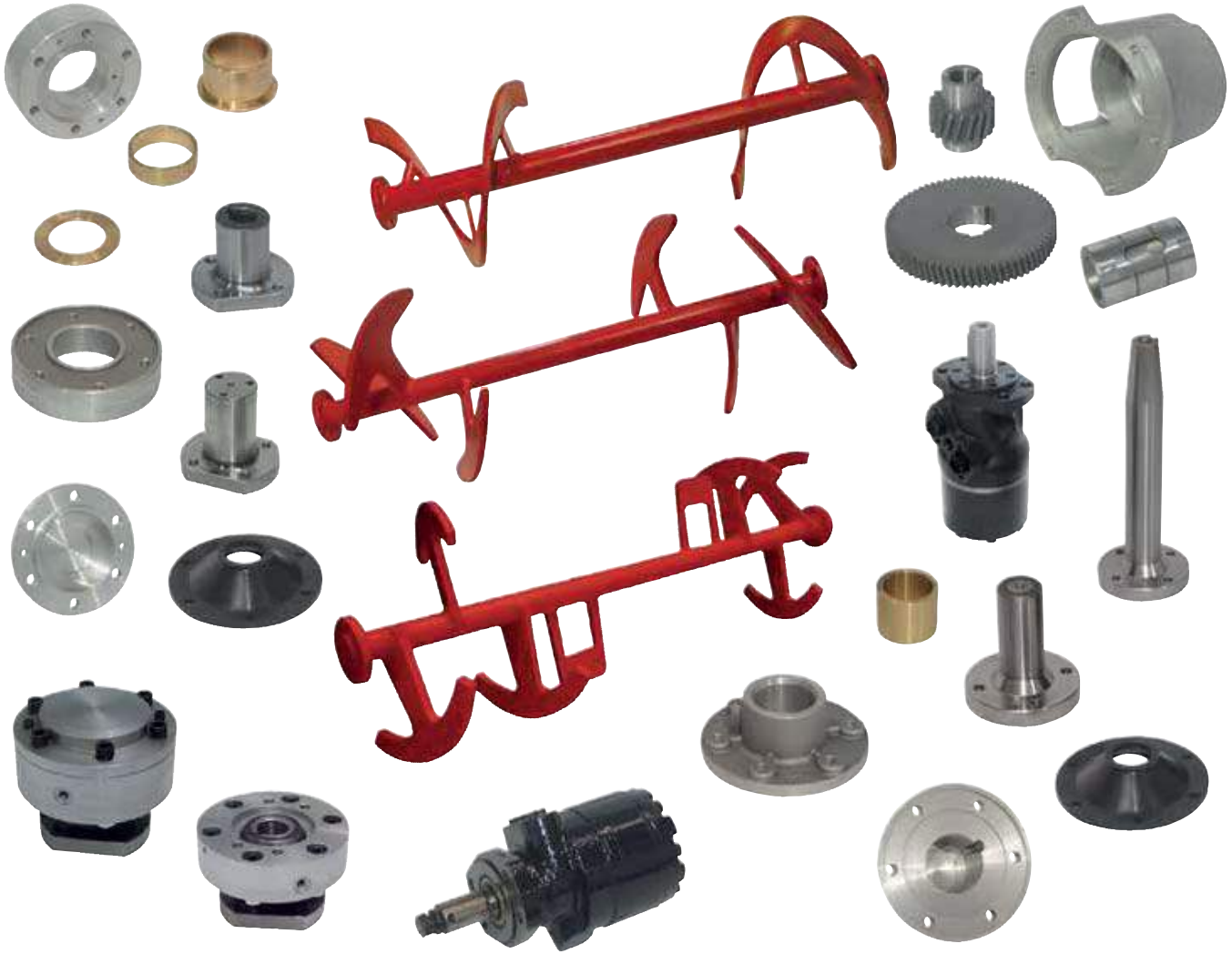

TRANSITION PIECE DN230

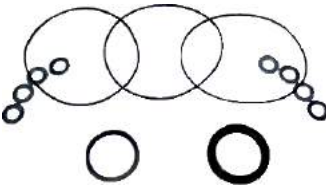

SCHWING

<p>İGS-2050</p> 	<p>İGS-2051</p> 	<p>İGS-2052</p> 	<p>İGS-2053</p> 
<p>HYDRAULIC MOTOR</p>	<p>SEAL SET</p>	<p>BEARING</p>	<p>SUPPORT</p>

<p>İGS-2054</p> 	<p>İGS-2055</p> 	<p>İGS-2056</p> 	<p>İGS-2057</p> 
<p>BUSHING</p>	<p>ORING</p>	<p>SEALING</p>	<p>FLANGED SHAFT</p>

<p>İGS-2058</p> 	<p>İGS-2059</p> 	<p>İGS-2060</p> 	<p>İGS-2061</p> 
<p>AGITATOR BEARING</p>	<p>FLANGED SHAFT</p>	<p>SPORT</p>	<p>SUPPORTING COVER</p>

<p>İGS-2062</p> 	<p>İGS-2063</p> 	<p>İGS-2064</p> 	<p>İGS-2065</p> 
<p>DISC</p>	<p>DISC</p>	<p>FLANGE BUSHING</p>	<p>FLANGED SHAFT BEARING SIDE</p>

<p>İGS-2066</p> 	<p>İGS-2067</p> 	<p>İGS-2068</p> 	<p>İGS-2069</p> 
<p>FLANGED SHAFT GEAR SIDE</p>	<p>COMPLETE GEAR BOX NEW</p>	<p>AGITATOR SHAFT COMPLETE</p>	<p>WATER PUMP</p>

<p>İGS-2070</p> 	<p>İGS-2071</p> 	<p>İGS-2072</p> 	<p>İGS-2073</p> 
<p>SEAL KIT FOR WATER PUMP</p>	<p>CLAMPING PIECE RIGHT</p>	<p>HNGE</p>	<p>COMPLETE GEAR BOX NEW</p>

İGS-2074



CONVEYING CYLINDER
200X219X1575

İGS-2075



CONVEYING CYLINDER
200X219X1776

İGS-2076



CONVEYING CYLINDER
200X219X2125

İGS-2077



CONVEYING CYLINDER
230 X 254 X 2125

İGS-2078







CONVEYING CYLINDER
250X273X2635



<p>iGS-2081</p> 	<p>iGS-2082</p> 	<p>iGS-2083</p> 	<p>iGS-2084</p> 
<p>PUMPING PISTON DN180</p>	<p>PUMPING PISTON DN200</p>	<p>PUMPING PISTON DN230</p>	<p>PUMPING PISTON DN250</p>

<p>iGS-2085</p> 	<p>iGS-2086</p> 	<p>iGS-2087</p> 	<p>iGS-2088</p> 
<p>HYDRAULIC PISTON</p>	<p>COUPLING GEAR</p>	<p>COUPLING GEAR</p>	<p>COUPLING GEAR</p>

<p>iGS-2089</p> 	<p>iGS-2090</p> 	<p>iGS-2091</p> 
<p>COUPLING GEAR</p>	<p>COUPLING PIECE</p>	<p>EMERGENCY PUSH BUTTON</p>

İGS-2092 	İGS-2093 	İGS-2094 	İGS-2095 
REMOTE CONTROL	VALVE CARTRIDGE PULSAR	FILTER ELEMENT	FILTER ELEMENT

İGS-2096 	İGS-2097 	İGS-2098 	İGS-2099 
BATTERY 7.2 V	OUTLET ELBOW 14 DEG.	REDUCTION ELBOW	ELBOW DN150

İGS-2100 	İGS-2101 	İGS-2102 	İGS-2103 
REDUCTION ELBOW	ELBOW DN180	O RING	TAPERED TUBE 1240MM

İGS-2104



TAPERED TUBE 1550MM

İGS-2105



TAPERED TUBE 1600MM

İGS-2106



TAPERED TUBE 2500MM

İGS-2107



TAPERED TUBE 3000MM



REİCH



İGS-5001



S VALVE

İGS-5002



SLEWING LEVER

İGS-5003



REAR BEARING

İGS-5004



FRONT BEARING

REICH

İGS-5005



WEAR BUSHING

İGS-5006

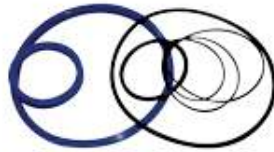

SEAL SET

İGS-5007



BUSHING

İGS-5008



BUSHING

İGS-5009



WEAR BUSHING

İGS-5010



BUSHING

İGS-5011



FLANGE BEARING

İGS-5012



FLANGE BEARING

İGS-5013



FLANGE BEARING

İGS-5014



SEALING DISC

İGS-5015



REDUCTION ELBOW

İGS-5016



RUBBER PISTON 200MM

İGS-5017



RUBBER PISTON 230MM

İGS-5018



AGITATOR GEAR BOX

İGS-5019



COUPLING



SERMAC



İGS-4001



S VALVE

İGS-4002



SLEWING LEVER

İGS-4003



OUTLET ELBOWİGS

İGS-4004



UNION

İGS-4005



SUPPORT

İGS-4006



COVER



İGS-4007 	İGS-4008 	İGS-4009 	İGS-4010 
WEAR PLATE	WEAR RING	SEAL RING	FLANGED SLEEVE

İGS-4011 	İGS-4012 	İGS-4013 	İGS-4014 
RING	BUSHING	BUSHING	SECTOR

İGS-4015 	İGS-4016 	İGS-4017 	İGS-4018 
BUSHING	BUSHING	SEAL SET	GASKET

İGS-4019



GASKET

İGS-4020



BUSHING

İGS-4021



DRIVE PIN

İGS-4022



DRIVE PIN

İGS-4023



HOUSING

İGS-4024



SUPPORT

İGS-4025



CONVEYING CYLINDER
230X254X2160

İGS-4026



RUBBER PISTON
230MM

İGS-4027



RING



CIFA

İGS-3001



S VALVE

İGS-3002



SLEWING LEVER

İGS-3003



BUSHING

İGS-3004



SUPPORT BUSHING

İGS-3005



BUSHING

İGS-3006



BUSHING

İGS-3007



WEAR BUSH

İGS-3008



WEAR PLATE

CİFA

İGS-3009



WEAR RING

İGS-3010







COLLOR

İGS-3011 	İGS-3012 	İGS-3013 	İGS-3014 
FLANGE	FLANGE	WEAR RING	SHAFT

İGS-3015 	İGS-3016 	İGS-3017 	İGS-3018 
SHAFT	GASKET	COUPLING	LEVER JOINT

İGS-3019 	İGS-3020 	İGS-3021 	İGS-3022 
SEAL SET	WATER PUMP	RUBBER PISTON 230	RUBBER PISTON 200

<p>İGS-3023</p> 	<p>İGS-3024</p> 	<p>İGS-3025</p> 	<p>İGS-3026</p> 
<p>SHOCK ABSORBER</p>	<p>GASGET</p>	<p>GASGET</p>	<p>OUTLET ELBOW</p>

<p>İGS-3027</p> 	<p>İGS-3028</p> 	<p>İGS-3029</p> 	<p>İGS-3030</p> 
<p>OUTLET ELBOW</p>	<p>COUPLING 7"</p>	<p>COUPLING 8"</p>	<p>UNION</p>

<p>İGS-3031</p> 	<p>İGS-3032</p> 	<p>İGS-3033</p> 	<p>İGS-3034</p> 
<p>CONVEYING CYLINDER 200X219X1680</p>	<p>CONVEYING CYLINDER 200X219X2150</p>	<p>CONVEYING CYLINDER 230X254X2200</p>	<p>ROTATION CYLINDER</p>

İGS-6013 	İGS-6014 	İGS-6015 	İGS-6016 
WEAR PUMP PULLEY TYPE	WATER PUMP	PNEUMATIC SYSTEM	SHAFT

İGS-6017 	İGS-6018 	İGS-6019 	İGS-6020 
GEAR FOR WATER PUMP	PLASTIC COUPLING	IMPELLER	FITTING

TRANSMİKSER

İGS-6021 	İGS-6022 	İGS-6023 	İGS-6024 
SEAL SET	WATER PUMP BEARING	CHUTE LOCK SET	

İGS-6025



GRETIN FITTING

İGS-6026



CHUTE HANDLE SUPPORT

İGS-6027



HAND PUMP

İGS-6028



HYDRAULIC CYLINDER
AL.TANK

TRANSMİKSER

İGS-6029



HYDRAULIC CYLINDER

İGS-6030



S HOSE

İGS-6031



MIXER CONTROL BOX
DOUBLE

İGS-6032



CONTROL CABLE

İGS-6033



MIXER CONTROL BOX
SINGLE

İGS-6034



BALANCE BALL

İGS-6035



SEAL FOR V CHUTE

İGS-6036



COUPLING 21 TEETH

İGS-6037



COUPLING 23 TEETH

İGS-6038



TEMPERATURE SWITCH

İGS-6039



TEMPERATURE SWITCH

İSG-6040



FILTER ELEMENT

İGS-6041



COMPLETE ROLLER
280X160

İGS-6042



EMPTY ROLLER
280X160

İGS-6043



COMPLETE ROLLER SET
280X160

İGS-6044



COMPLETE ROLLER
280X110

İGS-6045



EMPTY ROLLER 280X110

İGS-6046



COMPLETE ROLLER SET
280X110

İGS-6047



COVER FOR ROLLER

İGS-6048



PIN 35MM

TRANSMİKSER

<p>İGS-6049</p> 	<p>İGS-6050</p> 	<p>İGS-6051</p> 	<p>İGS-6052</p> 
<p>PIN 50MM</p>	<p>PIN 50MM</p>	<p>EMPTY ROLLER 250X110</p>	<p>COMPLETE ROLLER 220X110</p>

<p>İGS-6053</p> 	<p>İGS-6054</p> 	<p>İGS-6055</p> 	<p>İGS-6056</p> 
<p>EMPTY ROLLER 220X110</p>	<p>COUPLING</p>	<p>MIXER FELT</p>	<p>MIXER REDUKTOR SMALL NUT</p>

<p>İGS-6057</p> 	<p>İGS-6058</p> 
<p>MIXER REDUKTOR BIG NUT</p>	<p>MIXER SEAL SET</p>

<p>İGS-8001</p> 	<p>İGS-8002</p> 	<p>İGS-8003</p> 	<p>İSG-8004</p> 
<p>WEAR PLATES MB1700</p>	<p>WEAR PLATES MB1200</p>	<p>HİGH SUPPORT SPONGE MB1700</p>	<p>4 HİGH SUPPORT SPONGE MB1700</p>

<p>İGS-8005</p> 	<p>İGS-8006</p> 	<p>İGS-8007</p> 	<p>İGS-8008</p> 
<p>COMPACT VİBRATION MOUNTS</p>	<p>COMPACT VİBRATION MOUNTS</p>	<p>COMPACT VİBRATION MOUNTS</p>	<p>SUPPORT MOUNT</p>

<p>İGS-8009</p> 	<p>İGS-8010</p> 	<p>İGS-8011</p> 	<p>İGS-8012</p> 
<p>WEAR PLATES</p>	<p>RAMMER E-68 AS PET</p>	<p>RAMMER E-68 UPPER WEDGE</p>	<p>E-66 UPPER WEDGE</p>

İGS-8013



2155 HOUSING
SUPPORT MOUNT

İGS-8014



WEAR PLATES

İGS-8015



WEAR PLATES

İGS-8016



AŞINMA PLAKASI

İGS-8017



HB 2500 FRONT
SUPPO RT MOUNT

İGS-8018



HB2500 WEAR PLATE

İGS-8019



ATLAS COPPCO TEPE
TAKOZU

İGS-8020



ATLAS COPPCO TEPE
TAKOZU

İGS-8021



KAMA TAPASI

İGS-8022



PİM TAPASI

İGS-8023



RAMMER SHIELD

İGS-8024



MB1700 KAMA

İGS-8025



AŞINMA PLAKASI

İGS-8026



SB302 KAMA

İGS-8027



RAMMER AŞINMA
PLAKASI SAĞ

İGS-8028



RAMMER AŞINMA
PLAKASI SOL

İGS-8029



RAMMER YAN DESTEK
TAKOZU

İGS-8030



RAMMER YAN DESTEK
TAKOZU

İGS-8031



RAMMER YAN DESTEK
TAKOZU

İGS-8032



MSB700 YAN DESTEK
TAKOZU

KIRICILAR

SABİT BİLYALI RULMANLAR

6000 / 6200 / 6300 / 6400 / 16000 / 16100 / 61800 / 61900



- ZR** Tek metal kapak
- 2ZR** Çift metal kapak
- RSR** Tek conta kapak
- 2RSR** Çift conta kapak
- N** Dairesel sekman kanallı
- ZRN** Tek metal kapak ve dairesel sekman kanallı
- 2ZRN** Çift metal kapak ve dairesel sekman kanallı

TEK SIRALI SABİT BİLYALI RULMANLAR



6000 / 6200 / 6300 / 6400 SERİLERİ



16000 / 16100 SERİLERİ

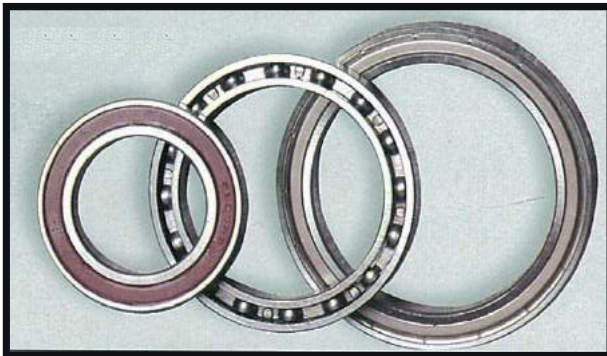

61800 / 61900 SERİLERİ



6000 / 6200 / 6300 / 6400 SERİLERİ

Tek sıralı sabit bilyalı rulmanlar radyal ve eksenel yükleri karşılar ve yüksek hızlarda çalışabilirler. Bu özelliklerinden dolayı en çok kullanılan rulman tipleridir. Açılabilirlik kapasiteleri sınırlıdır. Bundan dolayı takıldıkları yerlerin eksenel kaçıklıkları dikkatli bir şekilde kontrol edilmelidir.

ÇİFT SIRALI SABİT BİLYALI RULMANLAR

Tek Sıralı sabit bilyalı rulmanlarla aynı özelliklerde olup, çift sıralı olması sebebiyle daha fazla yük taşıma özelliğine sahiptir.



4200 / 4300 SERİLERİ

EĞİK BİLYALI OMUZLU RULMANLAR

7000 / 7100 / 7200 / 7300 / 3200 / 3300 / QJ



EĞİK BİLYALI RULMANLAR TEK SIRALI



7000 / 7100 / 7200 / 7300 SERİLERİ

DÖRT NOKTA RULMANLARI QJ SERİLERİ



Dört nokta rulmanları tek sıralı eğik bilyalı rulmanlar grubundan olup aksenal yükleri iki yönden de karşılar. İç ve dış bilezik hareket yollarının aksenal kesitteki profili, sivri kemerleri bulunan çember yayı şeklindedir. Dört nokta rulmanlarının bileziği iki parçalıdır.



EĞİK BİLYALI RULMAN / ÇİFT SIRALI

3200 / 3300 SERİLERİ



Çift sıralı eğik bilyalı rulman yapısı itibarıyla - O- düzeninde bir tek sıralı eğik bilyalı rulmandır. Bu rulman yüksek radyal kuvvetleri ve her iki yönde aksel kuvvetleri taşıyabilir.

OYNAK BİLYALI RULMANLAR

1200 / 1300 / 2200 / 23001 11200 / 11300 SERİLERİ



Oynak bilyalı rulmanlar çift sıra bilyalıdır ve dış bileşik hareket yolları küreseldir. Bu durum rulmana açılma yönünde oynaklık kazandırır. Eksen kaçıklıklarını mil esnemelerini ve yuva deformasyonlarını karşılamasını sağlar. Oynak bilyalı rulmanlar silindirik veya konik delikli.

SİLİNDİRİK MAKARALI RULMANLAR



Silindirik makaralı rulmanlar parçalarına ayrılabilir. Bu özellik takma ve sökmeyi kolaylaştırdığı gibi her iki rulman bileziği sıkı geçirilebilirler. Makaralar ve hareket yolları arasındaki iyileştirilmiş çizgisel temas kenar gerilmelerini önler. Fatura düzenine göre çeşitli tiplere ayrılır.

NU TİPİ



NU Tipinin dış bileziğinin iki faturası olup, iç bilezik faturasızdır.

N TİPİ



N Tipinin iç bileziğinin iki faturası olup, dış bilezik faturasızdır.

NU ve N tipindeki silindirik makaralı rulmanlar serbest rulmanlardır. Parçalara ayrılabilir olmaları takma ve sökmeyi kolaylaştırır. Her iki bileziğe sıkı geçirilebilir.

NJ TİPİ



NJ Tipindeki silindirik makaralı rulmanların dış bileziğinde iki fatura bulunur. Buna karşılık iç bilezikte tek fatura vardır. Böylece tek yöndeki aksel kuvvetleri karşılayabilirler.

NUP TİPİ



NUP tipindeki silindirik makaralı rulmanların dış bileziğinde iki fatura olup, iç bileziğinde sabit bir fatura ve serbest bir fatura kapağı bulunur. Değişken yöndeki aksel kuvvetleri karşılar.

SİLİNDİRİK MAKARALI RULMAN

NN TİPİ



NN tipindeki rulmanlar N tipinde olduğu gibi iç bileziğinin iki tarafı faturalıdır. Dış bilezik ise faturasızdır. NN tipindeki rulmanlar çift sıra silindirik makaralı rulmandır.

RNU TİPİ



RNU silindirik makaralı rulmanlar ile az yer kaplayan yataklamalar elde edilir. Burada makaralar doğrudan sertleştirilmiş ve taşlanmış mil üzerinde döner.

NJ ve HJ TİPİ



NJ tipindeki bir faturalı rulman HJ faturalı bileziğiyle birlikte kullanıldığında NUP rulmanı gibi bir sabit rulman oluşturur.

NU ve HJ TİPİ



NU tipindeki bir faturasız rulman HJ faturalı bileziğiyle birlikte kullanıldığında NJ tipindeki gibi tek faturalı bir göbek oluşturur.

NNU TİPİ



NNU tipindeki rulmanlar NN tipinde olduğu gibi çift sıralı silindirik makaralı rulmanlardır. NU tipinde olduğu gibi dış bileziğin iki tarafı da faturalıdır. İç bilezik ise faturasızdır.

OYNAK MAKARALI RULMANLAR

20000 / 21000 / 22000 / 23000 / 24000 SERİLERİ



OYNAK MAKARALI TEK SIRALI RULMANLAR

20200 / 20300 / 20400 SERİLERİ



Tek sıralı oynak makaralı rulmanlar bir sıra açısız uyabilme yeteneğine sahip makaralardan oluşmuş olup, radyal yönde taşıma kapasitesi oldukça yüksektir. Eksen kaçıklıklarının dengelenmesi istenen tasarımlar için oldukça uygundur. Parçalarına ayrılmayan bu rulmanlar silindirik ve konik delikli olarak mevcuttur.

21300 / 22200 / 22300 / 23000 / 23100 / 23200 / 23300 / 24000 / 24100 SERİLERİ



Oynak makaralı rulman en ağır zorlamalara uygun bir rulman tipidir. Bu rulman dış bileziğin oyuk küre biçimindeki hareket yoluna kendiliğinden uyabilen iki sıra simetrik yapıda makaraya sahiptir. Bu sayede mil eğilmeleri ve rulman oturma yerlerinin eksen kaçıklıkları dengelenir. Oynak makaralı rulmanlara büyük çap ve uzunluğa sahip olan makaralardan mümkün olan en fazla sayıda bulunur. Makaralar ile hareket yolları arasındaki iyi yaslanma sayesinde düzenli bir gerilim, dağılımı ve yüksek bir taşıma yeteneği elde edilir. Titreşimli yükler gibi özellikle ağır zorlamalar için daraltılmış ölçü ve artırılmış radyal boşlukta özel oynak makaralı rulmanlar vardır. Bu rulmanlar soneklerinden tanınır. Örneğin C4 - VA405- T41 F80 gibidir. Oynak makaralı rulmanlar konik delikli veya silindirik delikli olarakta değişir.

KONİK MAKARALI RULMANLAR

30200 / 30300 / 31300 / 32000 / 32200 / 32300 / 32900 / 33000 / 33100 / 33200



Sızdırmazlık elemanlı entegre- konik makaralı rulmanlar dışındaki konik makaralı rulmanlar, makara çemberli iç bilezik ve dış bilezik ayrı ayrı takılabilecek şekilde parçalarına ayrılabilir. Makaralar ile hareket yolu arasındaki düzeltilmiş çizgiler temas sayesinde kenar gerilmeleri önlenmiş olur. Konik makaralı rulmanlar aksel kuvvetleri sadece tek yönde karşılayabileceğinden karşı klavuzlanma için genellikle ikinci bir konik makaralı rulmanın ters yönde takılması gerekir.

EKSENEL OYNAK MAKARALI RULMAN

29200 / 29300 / 29400 SERİLERİ



Eksenel- oynak makaralı rulmanlar büyük aksel kuvvetleri taşır ve nisbeten yüksek devir hızlarına uygunluk gösterir. Yatak eksenine göre eğik olan hareket yolları sayesinde rulman radyal yükleri de karşılayabilir. Radyal yük aksel kuvvetin %55 den küçük olmalıdır.

KONİK MAKARALI RULMAN (D SERİLERİ)



İki sıralı bir rulman tipi olan TDO tek parçalı (çift) bir dış bilezikten ve iki tek iç bilezikten oluşmuştur. Bu konfigürasyon baş aşağı devrilme anlarında ortaya çıkan yükleri desteklemek için geniş bir efektif rulman yanal saçılması sağlar. TDO rulmanlar ayrıca sabit konumlarda kullanılabilirler ya da mil genişlemesini karşılamak için yuva deliği içinde yüzmeye bırakılabilirler.

EKSENEL SABİT BİLYALI RULMANLAR

51100 / 51200 / 51300 / 51400 / 52200 / 52300 / 52400 SERİLERİ



Eksenel sabit bilyalı rulmanlar tek ve çift yönlü tasarım olarak üretilir. Bu rulmanlar yüksek eksenel yönleri karşılamlarına karşın radyal yük taşımazlar. Düzlemsel oturma yüzeyli alışılmış tasarıma ilaveten küresel yuva diskli ve oturma bilezikli eksenel bilyalı rulmanlar vardır.

EKSEN EL SABİT BİLYALI TEK YÖNLÜ RULMAN

51000 SERİLERİ



EKSENEL SABİT BİLYALI TEK YÖNLÜ RULMAN

52000 SERİLERİ



EKSENEL SİLİNDİRİK MAKARALI RULMANLAR



Eksenel - silindirik makaralı rulmanlar ile rijid taşıma kapasitesi yüksek ve darbelere karşı duyarız yataklamalar elde edilir. Rulmanın parçalarının basit yapısı birçok kombinasyonun yapılmasını olanaklaştırır. Örneğin eksenel silindirik makaralı rulmanın taşlanmış kapaklı eksenel iğneli çemberler ile beraber takılabilir. Daha basit yataklamalarda terside yapılabilir ve eksenel iğneli çemberlerde normal olarak kullanılan hareket kapakları ve eksenel kapaklar eksenel silindirik makaralı çemberler ile de birleştirilebilir. Eksenel silindirik makaralı rulmanlar eksenel bilyalı veya eksenel iğneli rulmanların taşıma kapasitesinin yetersiz kaldığı durumlarda kullanılır.

YATAKLI RULMANLAR



Rulmanların yanı sıra özel kullanım yerlerine göre değişen montaj pratik rulman tipleridir. Kullanım yerlerine göre değişik tip ve ölçülerde üretilir.

UCP SERİSİ



UCF SERİSİ

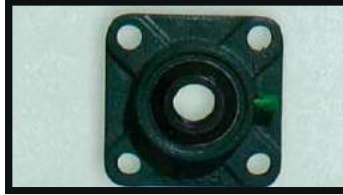

UCFL SERİSİ



UCFA SERİSİ



UCFC SERİSİ



UCFB SERİSİ



UCPH SERİSİ



UCT SERİSİ



UCPA SERİSİ



SAC YATAK ÇEŞİTLERİ

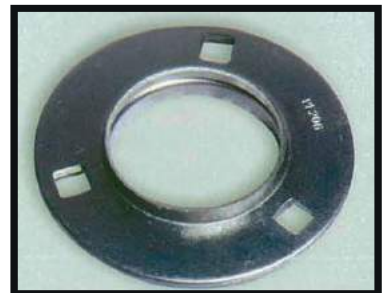

İĞNELİ RULMANLAR

HK- NK- NKI - NKIS - NAX- NAXK- NAO - NA- RNA- NA TR- NUTR SERİLERİ



NKS SERİSİ İĞNELİ RULMANLAR



İĞNELİ RULMANLAR / İÇ BİLEZİKSİZ
NK- NKJ / RNA SERİLERİ

İĞNELİ RULMANLAR
HK SERİLERİ

NATR SERİLERİ / YANAK PULU ÜZERİNDEN
EKSEN EL KLAVUZLUDUR.

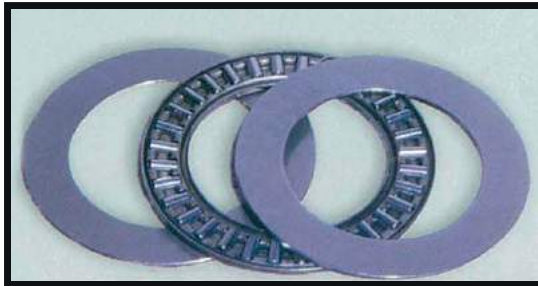

AS 1 AXK EKSEN EL İĞNELİ RULMANLAR



NKX İĞNELİ EKSENEL BİLYALI RULMANLAR



KRTİPİ İĞNELİ RULMANLAR
SAFT FATURASI VE YANAK
PULU ÜZERİNDEN EKSENEL
KLAVUZLAMA



MAFSALLAR VE MAFSAL KAFALI RULMANLAR

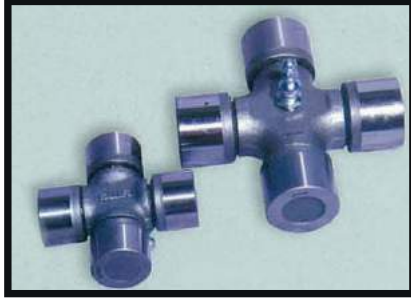

MAFSAL - İSTAVROZ



PHS SERİSİ
MAFSAL KAFALI RULMAN



POS SERİSİ
MAFSAL KAFALI RULMAN



GE SERİSİ MAFSALLAR



ZBL SERİSİ
BAĞLANTI MAFSALI

TANE MİSKET VE MASURALAR

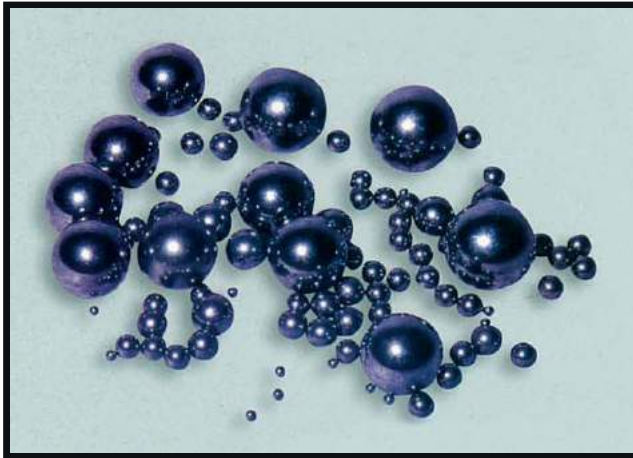

OTOMOTİV RULMANLARI



LİNEER RULMANLAR VE KLAVUZLANMA SİSTEMLERİ

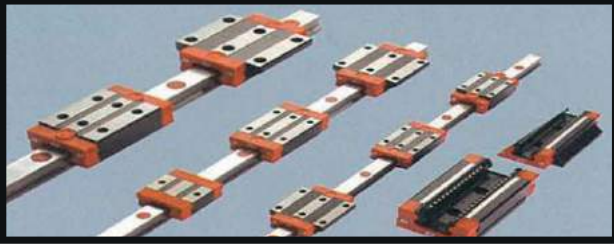

LİNEER ARABA VE YAYLAR



VİDALI MİLLER

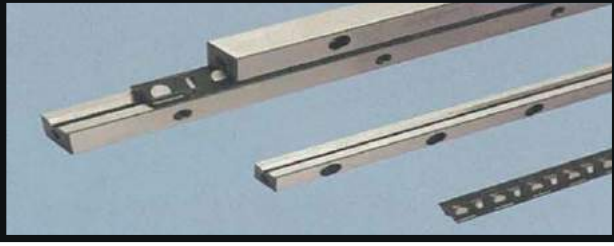

HASSAS LNEAR KIZAKLAR



VİDALI MİL YATAKLARI

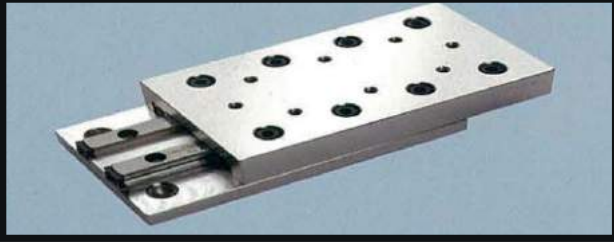

LİNEER KIZAKLAR

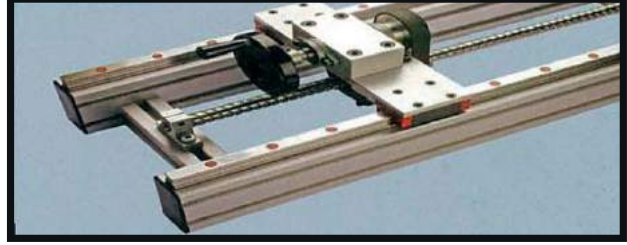

LİNEER KIZAKLI MODÜLLER



VİDALI MİL UÇ YATAKLARI



LİNEER ARABALI KIZAKLAR



VİDALI MİL UÇ YATAKLARI



LME TİPİ LNEAR RULMANLAR

RULMAN YATAKLARI

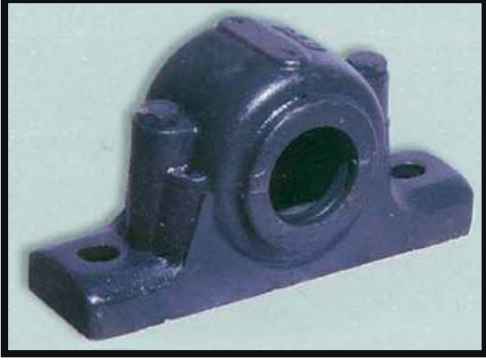

SN TİP YATAKLAR



SNH TİP YATAKLAR



722500 DB SERİLERİ AÇIK TİP RULMAN YATAKLARI



722500 DA SERİLERİ KAPALI TİP RULMAN YATAKLARI



SD SERİLERİ AĞIR TİP RULMAN YATAKLARI

MAŞONLAR



H -AH - AOH - AHX TİPİ MAŞONLAR



H 200 / H 300 / H 2300 / H 3100 GERME MAŞONLAR



AH TİPİ ÇAKMA MAŞONLAR

TIRNAKLI SOMUN VE PULLAR



TIRNAKLI SOMUNLAR

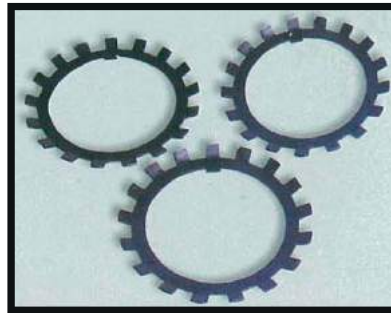

TIRNAKLI PULLAR

TESPİT BİLEZİKLERİ

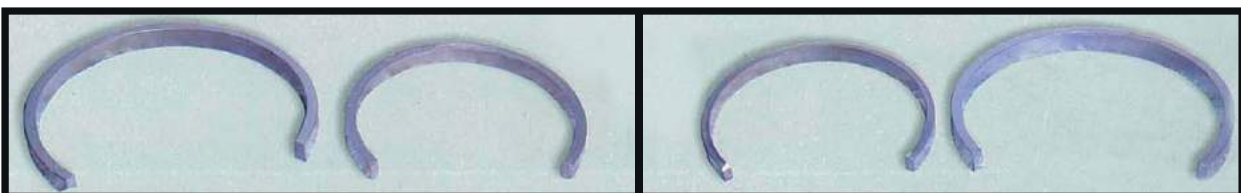

FRM / FRB SERİLERİ

GÜÇ AKTARMA ELEMANLARI

BURÇLU KASNAKLAR

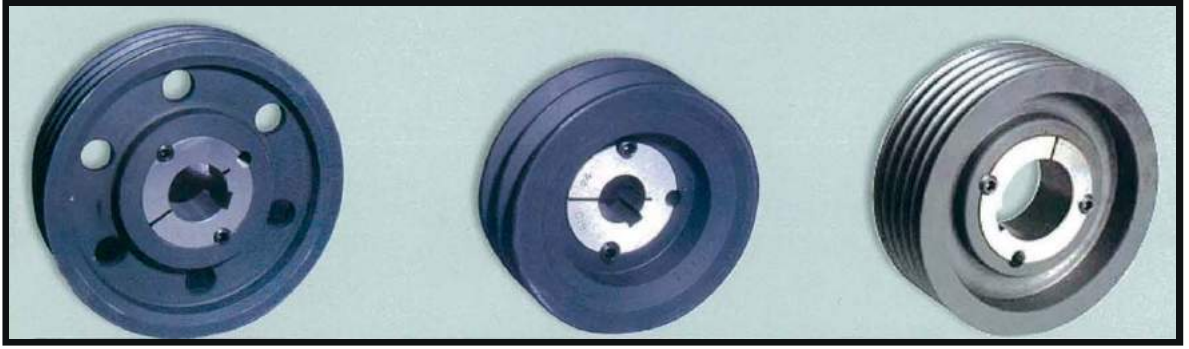

TRİGER KASNAKLAR



Çağımızda teknolojinin ilerlemesi ile makina ekipmanlarının takılıp sökülmesi ve kullanımı daha kolay ve pratik hale gelmiştir. Burçlu kasnakların kasnağı ve göbek kısmı ayrı ayrı olduğundan montajı kolaydır. Kendinden balanslı olması sebebiyle herhangi bir ikinci işlem gerektirmez.

DÖKÜM V KASNAKLARI



13-17-22-25MM / DÖKÜM V KASNAKLARI

ÖZEL DÖKÜM V KASNAKLARI

ÖZEL DÖKÜM KADEMELİ V KASNAKLARI

ZİNCİR VE DİŞLİ ÇEŞİTLERİ

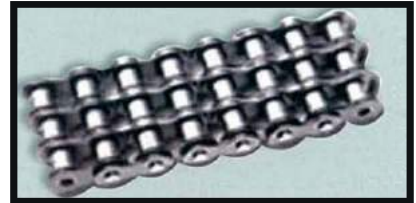
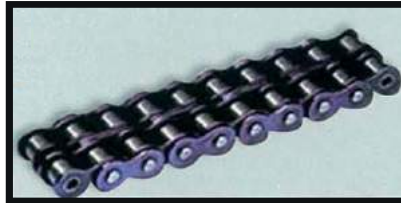
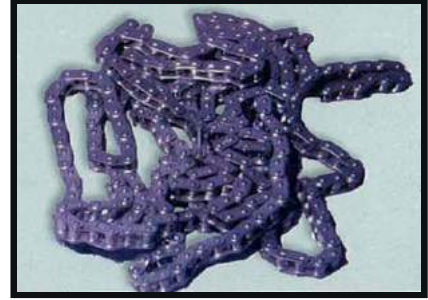
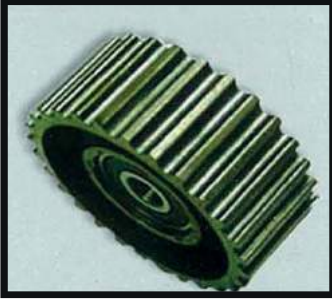
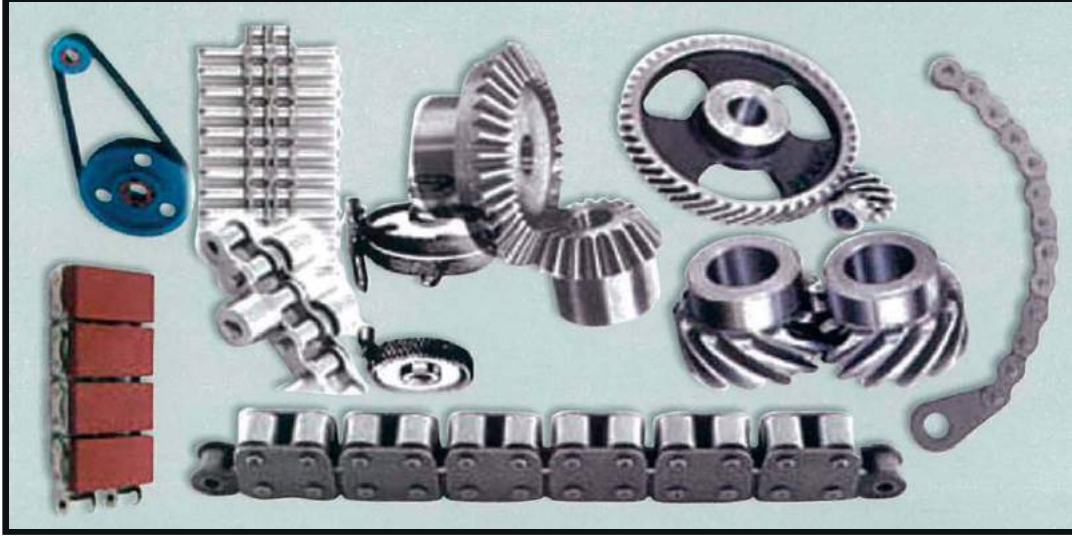

TEK SIRALI ZİNCİRLER

ÇİFT SIRALI ZİNCİRLER

ÜÇ SIRALI ZİNCİRLER

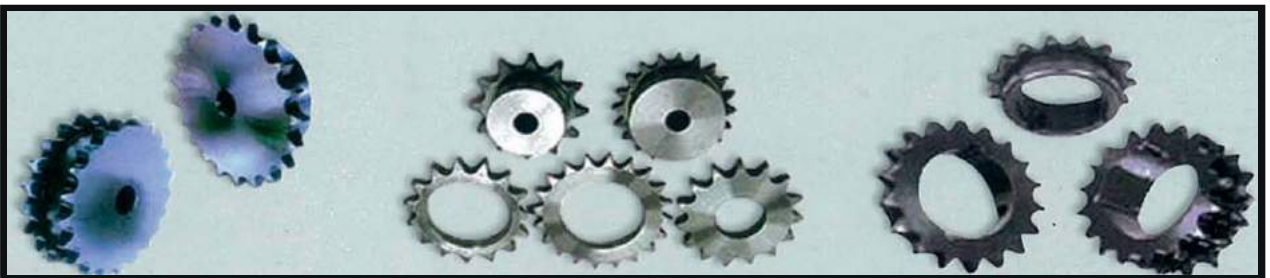

DİŞLİ ÇEŞİTLERİ



ZİNCİR EK VE KİLİTLERİ

BRONZ BURÇLAR



MİSKETLİ BURÇLAR



YUMUŞAK UÇLU BURÇLAR



ÇELİK BURÇLAR



KENDİNDEN YAĞLAMALI METAL BURÇLAR



BRONZ BURÇLAR



DÖKÜM BRONZ BURÇLAR



SİNER BRONZ BURÇLAR



KENDİNDEN YAĞLAMALI BURÇLAR

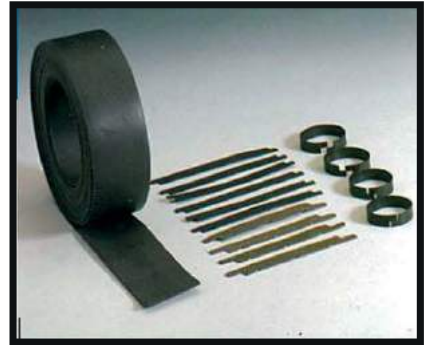

YUMUŞAK PTFE ŞERİTLER



YAĞLAMASIZ BURÇLAR



AZ YAĞLAMALI BURÇLAR



METAL BURÇLAR

V KAYIŞLARI



V KAYIŞLARI



BANDED V KAYIŞLARI

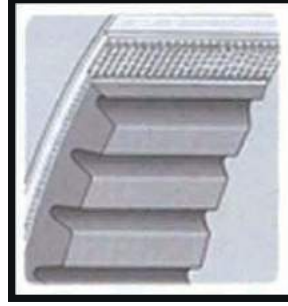

VARYATÖR KAYIŞLARI



KANALLI KAYIŞLAR



ALTİGEN KAYIŞLAR



POLİÜRETAN V KAYIŞLARI



ÖZEL KAPLAMA KAYIŞLAR



ÖZEL PROFİLLİ KAYIŞLAR



DAİRESEL ÖRGÜ MAKİNASI
KAYIŞLARI



ÖZEL VE GÜÇLENDİRİLMİŞ
ZAMAN KAYIŞLARI



POLİÜRETAN
ZAMAN KAYIŞLARI

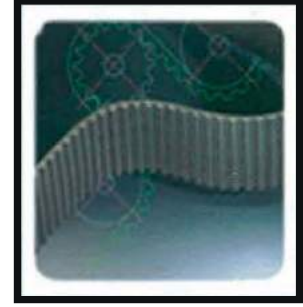

AÇIK UÇLU KAUÇUK
ZAMAN KAYIŞLARI



AÇIK UÇLU POLİÜRETAN ÇELİK
TELLİ ZAMAN KAYIŞLARI



POLİÜRETAN ÇELİK TELLİ
DÜZ KAYIŞLAR



YUVARLAK KAYIŞLAR VE
PNOMATİK HORTUMLAR



YÜKSEK PERFORMANSLI
BAKLALI V KAYIŞLAR



DÜZ KAYIŞLAR



KONVEYOR BANTLAR

V KAYIŞLARI



SANAYİ TİP TEKERLEKLER



KORUYUCU YAĞLAR VE SPREYLER



DÖNER MİL YAĞ KEÇESİ TANIMI

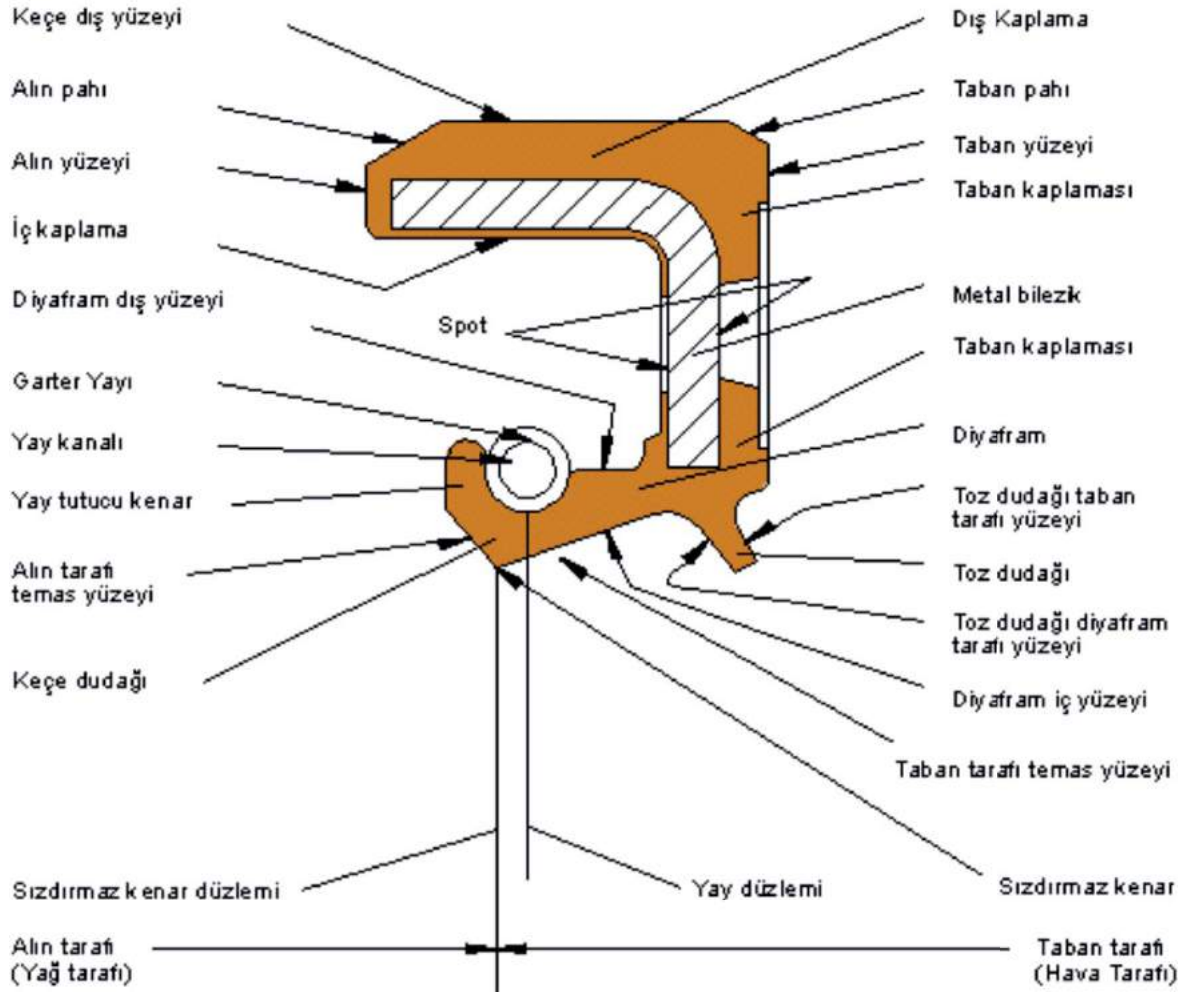



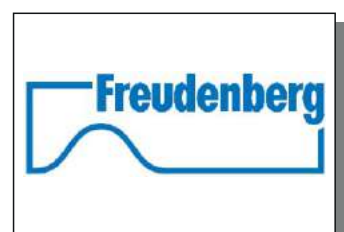



ASO 1. OSB. ASO Bulv. BC Blok No:1-B 17/C Sincan / ANKARA

0.312 267 11 10 - 0.532 523 74 56 0.312 267 11 09

info@ilkimgrup.com
sener@ilkimgrup.com

www.ilkimgrup.com



www.ilkimkauçuk.com

